

X-BAND LNA MMIC

FEATURES:

- 7.0 – 11.0 GHz Operating Bandwidth
- 1.1 dB Noise Figure
- 21 dB Small-Signal Gain
- 12 dBm Output Power
- +3V Single Bias Supply
- DC De-coupled Input and Output Ports

GENERAL DESCRIPTION:

The FMA219 is a 2-stage, reactively matched pHEMT low-noise MMIC amplifier designed for use over 7.0 to 11.0 GHz. The amplifier requires a single +3V supply and one off-chip component for supply de-coupling. Both the input and output ports are DC de-coupled. Grounding of the amplifier is provided by plated thru-vias to the bottom of the die, no additional ground is required. The amplifier is unconditionally stable over all load states (-45 to +85°C), and conditionally stable if the input port is open-circuited.

LAYOUT:

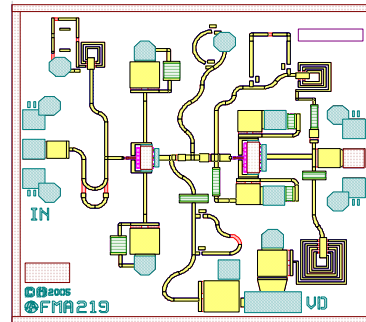

TYPICAL APPLICATIONS:

- Low noise front end amplifiers
- General X-Band gain block

ELECTRICAL SPECIFICATIONS:

PARAMETER	SYMBOL	CONDITIONS	MIN	TYP	MAX	UNITS
Operating Frequency Bandwidth	BW	VDD = +3 V IDD = IOP	7		11	GHz
Small Signal Gain	S21	VDD = +3 V IDD = IOP	19	21	23	dB
Operating Current	IOP	No RF input	50	65	80	mA
Small Signal Gain Flatness	ΔS_{21}	VDD = +3 V IDD = IOP		± 0.5	± 0.8	
Noise Figure	NF	VDD = +3 V, IDD = IOP		1.1	1.4	dB
3rd Order Intermodulation Distortion	IMD	VDD = +3 V, IDD = IOP POUT = +1.5 dBm SCL		-47		dBc
Power at 1dB Compression	P1dB	VDD = +3 V	11.5	12.5		dBm
Input Return Loss	S11	VDD = +3 V IDD = IOP		-7	-3	dB
Input Return Loss @ 9.5GHz + 10GHz	S11(9.5+10GHz)	VDD = +3 V IDD = IOP			-4	dB
Output Return Loss	S22	VDD = +3 V IDD = IOP		-16	-10	dB
Reverse Isolation	S12	VDD = +3 V IDD = IOP		-40	-30	dB

Note: T_{AMBIENT} = 22°C

ABSOLUTE MAXIMUM RATING¹:

PARAMETER	SYMBOL	TEST CONDITIONS	ABSOLUTE MAXIMUM
Supply Voltage	VDD	For any operating current	6V
Supply Current	IDD	For VDD < 5V	100mA
RF Input Power	PIN	For standard bias conditions	5dBm
Storage Temperature	TSTG	Non-Operating Storage	-40°C to 150°C
Total Power Dissipation ^{2,3}	PTOT	See De-Rating Note below	750mW
Gain Compression	Comp.	Under any bias conditions	5dB
Thermal Resistance ⁴	ΘJC	750mW dissipation, heatsink temp 22°C	175°C/W

Notes:

1. T_{Ambient} = 22°C unless otherwise noted; exceeding any one of these absolute maximum ratings may cause permanent damage to the device
2. Total Power Dissipation is defined as: $P_{TOT} = P_{DC} + P_{IN} - P_{OUT}$
 where P_{DC} = DC Bias Power, P_{IN} = RF Input Power, P_{OUT} = RF Output Power
 Total Power Dissipation shall be de-rated above 22°C as follows:
 $P_{TOT} = (150 - T_{CASE}) / \Theta_{JC} \text{ W}$
 where T_{CASE} = Temperature of the on the underside of the package or substrate
3. The quoted Thermal Resistance value is a worst-case figure assuming Gold/Tin die attach onto a Copper substrate. The use of epoxy die attach and substrate materials of lower thermal conductivity will increase the Thermal Resistance. Further information and assistance is available on request.
4. Θ_{JC} increases linearly from 175°C/W at a T_{CASE} of 22°C to 210°C/W at a T_{CASE} of 145°C

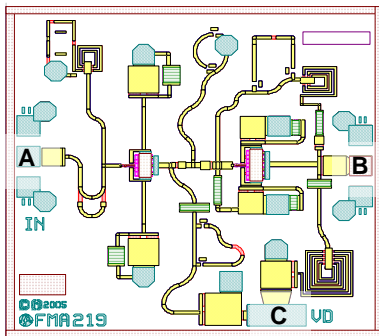
PAD LAYOUT:

	PAD NAME	DESCRIPTION	PIN COORDINATES (μm)
A	IN	RFIN	102, 888
B		ROUT	1527, 843
C	VD	Drain Voltage	1177, 103

Note: Co-ordinates are referenced from the bottom left hand corner of the die to the centre of bond pad opening

DIE SIZE (μm)	DIE THICKNESS (μm)	MIN. BOND PAD PITCH (μm)	MIN. BOND PAD OPENING (μm x μm)
1624 x 1624	100	>150	92 x 92

TYPICAL MEASURED PERFORMANCE ON WAFER:

 Note: Measurement Conditions $T_{\text{AMBIENT}} = 22^{\circ}\text{C}$ unless otherwise stated

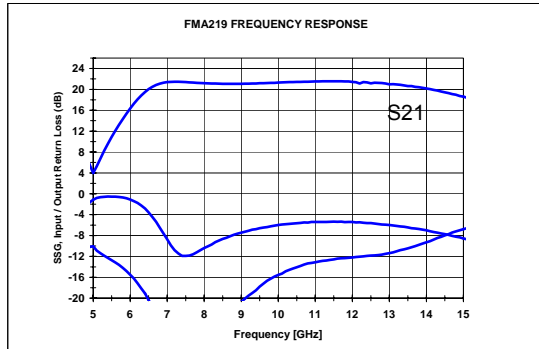
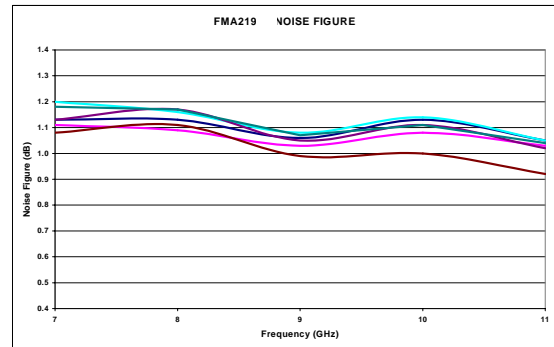
RF PERFORMANCE ($V_{\text{DD}} = +3\text{V}$, $I_{\text{DD}} = I_{\text{OP}}$)

NOISE FIGURE

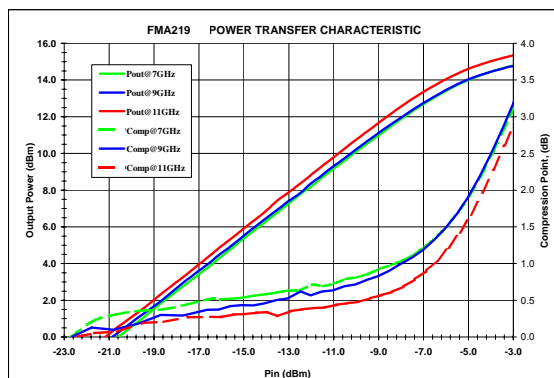
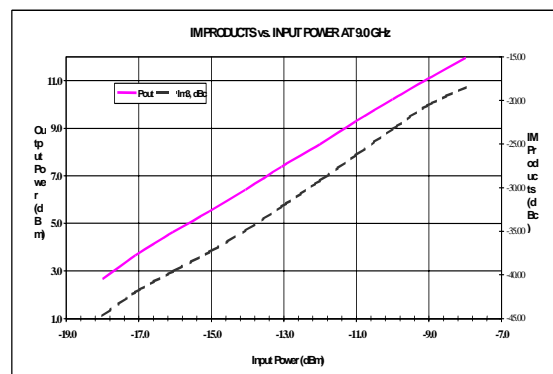
Note: Multiple traces show typical die variation across a 150mm (6") wafer. Effect of typical bond wire inductances (25 μm dia. 1mm length, 2 each on input and output ports) is less than a 0.5dB decrease in S21 (@11GHz), and no measurable effect on noise figure.

POWER TRANSFER CHARACTERISTIC

3RD-ORDER INTERMODULATION

Note: Equivalent output IP3 performance exceeds 24dBm, input IP3 is typically $\geq +2\text{dBm}$.

S-PARAMETERS (Vdd= 3.0V; Idd= 72mA):

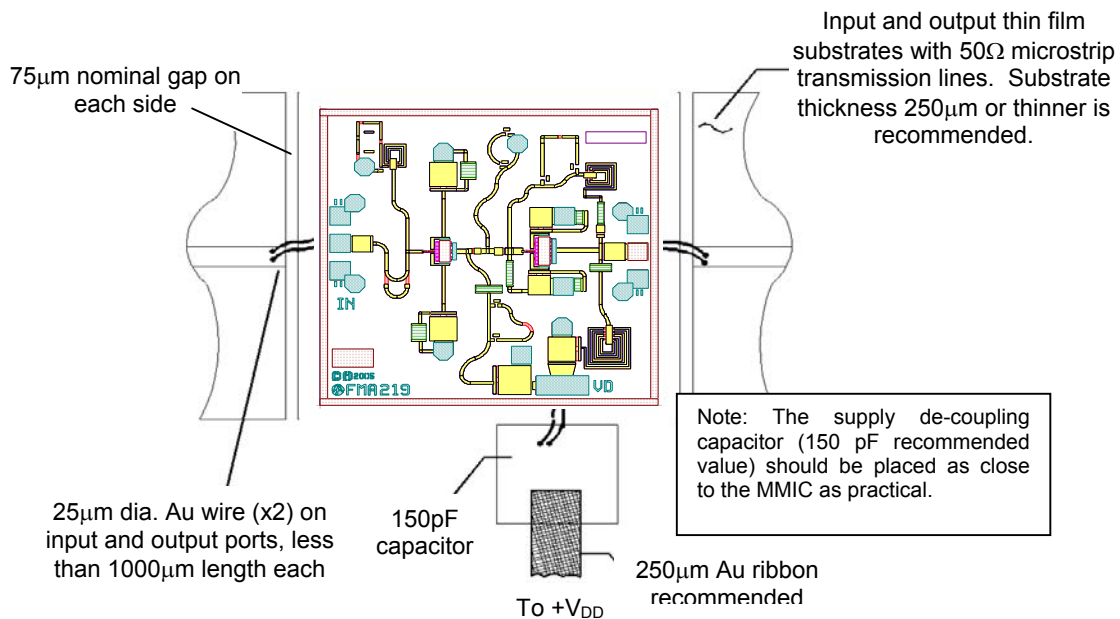
FREQ-GHZ	S11MAG	S11ANG	S21MAG	S21ANG	S12MAG	S12ANG	S22MAG	S22ANG
1	0.974	-106.62	0.068	-115.04	0	107.89	0.74	-117.91
1.245	0.968	-125.3	0.079	-144.82	0	96.58	0.641	-135.03
1.49	0.963	-141.67	0.092	-165.53	0.001	76.88	0.568	-147.1
1.735	0.959	-156.2	0.096	168.17	0.001	55.16	0.514	-156.86
1.98	0.958	-169.47	0.1	145.39	0	53.04	0.474	-164.33
2.225	0.96	178.08	0.104	123.02	0.001	46.09	0.445	-170.58
2.47	0.965	166.1	0.112	99.66	0.001	23.97	0.421	-176
2.715	0.973	154.02	0.132	73.18	0.001	42.06	0.402	179.01
2.96	0.958	141.23	0.148	45.25	0.001	52.06	0.386	174.19
3.205	0.934	131.54	0.171	31.12	0.001	18.31	0.37	169.6
3.45	0.95	121.28	0.251	16.56	0.001	-4.07	0.356	165.04
3.695	0.968	109.94	0.367	0.21	0.001	3.18	0.342	160.47
3.94	0.988	97.76	0.535	-15.43	0.002	-9.97	0.328	155.92
4.185	1.007	84.85	0.778	-30.42	0.002	-30.48	0.312	151.5
4.43	1.035	70.66	1.151	-45.48	0.002	-27.77	0.296	147.18
4.675	1.069	54.25	1.771	-62.52	0.003	-49.44	0.281	143.68
4.92	0.951	28.15	2.926	-102.1	0.009	-120.99	0.305	140.84
5.165	0.945	29.43	2.061	-105.45	0.004	118.66	0.259	124.29
5.41	1.021	10.5	3.203	-113.56	0.003	65.1	0.222	118.27
5.655	1.034	-9.95	4.536	-131.16	0.004	24.75	0.19	111.03
5.9	1.004	-31.51	6.024	-151.54	0.005	-1.95	0.156	103.14
6.145	0.927	-53.66	7.547	-173.34	0.006	-23.74	0.12	95.2
6.39	0.807	-75.49	8.943	164.5	0.007	-45.39	0.085	88.64
6.635	0.658	-95.15	10.049	142.79	0.009	-65.6	0.055	84.7
6.88	0.504	-111.08	10.815	122.24	0.01	-82.43	0.032	83.47
7.125	0.367	-120.38	11.268	103.33	0.01	-97.87	0.013	87.06
7.37	0.268	-119.71	11.522	86.07	0.011	-113.2	0.003	-101.15
7.615	0.227	-109.46	11.667	70.26	0.011	-125.36	0.018	-91.84
7.86	0.24	-99.07	11.737	55.61	0.012	-137.61	0.033	-91.39
8.105	0.283	-96.28	11.775	41.94	0.012	-146.86	0.049	-91.83
8.35	0.337	-99.06	11.806	28.96	0.013	-157.24	0.065	-92.12
8.595	0.388	-105.01	11.826	16.67	0.013	-165.6	0.081	-93.19
8.84	0.435	-111.94	11.843	4.87	0.014	-174.09	0.098	-94.77
9.085	0.478	-119.7	11.844	-6.52	0.014	178.62	0.114	-96.84
9.33	0.514	-127.72	11.852	-17.58	0.015	170.72	0.129	-99.55
9.575	0.545	-135.89	11.846	-28.41	0.015	163.57	0.144	-102.25
9.82	0.572	-143.88	11.827	-39.01	0.016	157.72	0.158	-104.77
10.065	0.593	-151.64	11.781	-49.39	0.016	150.1	0.171	-107.68
10.31	0.608	-159.12	11.726	-59.5	0.016	143.61	0.183	-110.27
10.555	0.618	-166.45	11.649	-69.51	0.017	136.33	0.193	-112.92
10.8	0.626	-173.69	11.557	-79.38	0.017	128.78	0.202	-115.51
11.045	0.63	179.26	11.432	-89.1	0.017	123.33	0.208	-117.39
11.29	0.627	172.58	11.269	-98.68	0.017	117.93	0.213	-119.05
11.535	0.622	166.17	11.091	-108.08	0.018	111.68	0.217	-120.38
11.78	0.615	160.01	10.896	-117.3	0.017	107.41	0.22	-121.13
12.025	0.604	154.16	10.683	-126.44	0.018	101.82	0.222	-121.27
12.27	0.589	148.47	10.437	-135.33	0.018	96.04	0.225	-120.82
12.515	0.575	142.93	10.175	-144.15	0.018	91.31	0.229	-120.02
12.76	0.561	137.71	9.907	-152.79	0.018	85.97	0.235	-118.85
13.005	0.544	133.07	9.609	-161.3	0.018	82.16	0.244	-117.85
13.25	0.524	128.55	9.318	-169.65	0.018	77.5	0.254	-116.67
13.495	0.506	124.13	9.005	-177.82	0.018	73.7	0.266	-115.65
13.74	0.488	119.86	8.698	-173.99	0.018	70.16	0.282	-114.8
13.985	0.469	115.96	8.368	166.14	0.018	64.24	0.3	-114.41
14.23	0.451	112.04	8.03	158.31	0.018	61.86	0.321	-114.35
14.475	0.434	108.26	7.686	150.71	0.017	57.54	0.344	-115.16
14.72	0.418	105.67	7.342	143.44	0.017	54.93	0.367	-116.62
14.965	0.397	102.87	7.02	136.17	0.017	52.45	0.388	-118.17
15.21	0.378	99.79	6.696	129.12	0.017	48.74	0.409	-120.11
15.455	0.361	96.52	6.365	122.22	0.017	45.51	0.429	-121.83
15.7	0.348	93.94	6.054	115.62	0.017	41.29	0.45	-123.8
15.945	0.333	92.37	5.737	109.22	0.017	40.04	0.471	-125.99

RECOMMENDED ASSEMBLY SCHEMATIC:

PREFERRED ASSEMBLY INSTRUCTIONS:

GaAs devices are fragile and should be handled with great care. Specially designed collets should be used where possible.

The back of the die is metallised and the recommended mounting method is by the use of conductive epoxy following the manufacturer's recommended curing temperature. For eutectic 80/20 gold/tin solder, use a stage temperature of 280-300°C for a maximum time of 60s. Use forming gas (90%N₂, 10% H₂) for best results.

Recommended lead bond technique is thermocompression wedge bonding with 25µm diameter wire. The bond tool force shall be 35-38g. Bonding stage temperature shall be 230-240°C, heated tool (150-160°C) is recommended. Ultrasonic bonding is not recommended.

HANDLING PRECAUTIONS:

To avoid damage to the devices care should be exercised during handling. Proper Electrostatic Discharge (ESD) precautions

should be observed at all stages of storage, handling, assembly, and testing. These devices should be treated as Class 0 (0-250 V) as defined in JEDEC Standard No. 22-A114. Further information on ESD control measures can be found in MIL-STD-1686 and MIL-HDBK-263.

APPLICATION NOTES & DESIGN DATA:

Application Notes and design data including S-parameters are available on request

DISCLAIMERS:

This product is not designed for use in any space based or life sustaining/supporting equipment.

ORDERING INFORMATION:

PART NUMBER	DESCRIPTION
FMA219	Die