

Product Description

Sirenza Microdevices' STA-5063Z is a general purpose class A linear amplifier which utilizes InGaP GaAs Heterojunction Bipolar Transistor (HBT) amplifier housed in a low-cost surface-mountable plastic package. This product is specifically designed as a driver amplifier for WLAN 802.11a and 5.8GHz ISM band and 3.3-3.8GHz fixed wireless applications. It can run from a fixed 3.0-3.6V supply with its on chip active bias network which includes a power up and down control. On-chip impedance matching circuitry provides a 50Ω nominal RF input and output impedance. Its high linearity makes it an ideal choice for multicarrier and digital applications. Housed in an industry standard SOT-363 package, it has no blind solder joints and designed for low cost. This product is offered in a RoHS Compliant and Green package with matte tin finish, designated by the "Z" package suffix.

Functional Block Diagram

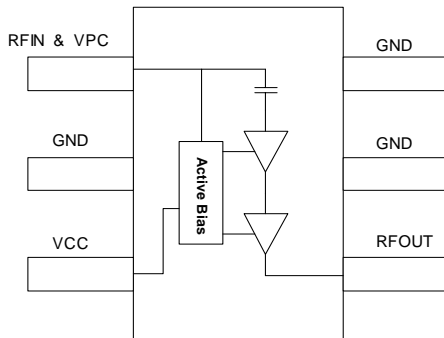

Key Specifications

Symbol	Parameters: Test Conditions Evaluation Board, $Z_0 = 50\Omega$, $V_{CC} = 3.3V$, $I_q = 52mA$, $T = 25^\circ C$	Unit	Min.	Typ.	Max.
f_o	Frequency of Operation	GHz	3.3		6.2
P_{1dB}	Pout at 1dB Compression – 3.5 GHz with 3GHz app circuit	dBm		17.5	
	Pout at 1dB Compression – 5.1 GHz with 5GHz app circuit			15	
	Pout at 1dB Compression – 5.9 GHz with 5GHz app circuit		13.5	15	
S_{21}	Small Signal Gain – 3.5 GHz with 3.5GHz app circuit	dB	17.5	19	21
	Small Signal Gain – 5.1 GHz with 5GHz app circuit		13.2	14.7	16.7
	Small Signal Gain – 5.9 GHz with 5GHz app circuit		12.5	14	16
VSWR In	Input VSWR 5.1-5.9GHz for 5GHz app circuit	-		1.5	2.0
VSWR Out	Output VSWR 5.1-5.9GHz for 5GHz app circuit	-		2.0	2.6
OIP3	Output Third Order Intercept @ 3.5GHz	dBm	28	30	
OIP3	Output Third Order Intercept @ 5.9GHz	dBm	25	27	
NF	Noise Figure @ 5.9 GHz	dB		9	10.5
I_{SUPPLY}	Total Device Current	mA	42	52	62
$R_{th, j-l}$	Thermal Resistance (junction - lead)	$^\circ C/W$		150	

The information provided herein is believed to be reliable at press time. Sirenza Microdevices assumes no responsibility for inaccuracies or omissions. Sirenza Microdevices assumes no responsibility for the use of this information, and all such information shall be entirely at the user's own risk. Prices and specifications are subject to change without notice. No patent rights or licenses to any of the circuits described herein are implied or granted to any third party. Sirenza Microdevices does not authorize or warrant any Sirenza Microdevices product for use in life-support devices and/or systems.

Copyright 2002 Sirenza Microdevices, Inc. All worldwide rights reserved.

303 S. Technology Court
Broomfield, CO 80021

Phone: (800) SMI-MMIC

1

<http://www.sirenza.com>
EDS-102990 Rev E

STA-5063Z



3.3 – 6.2 GHz General Purpose 3.3V 15dBm Amplifier



SOT-363
2mm x 2.1mm

Product Features

- Linear Class A Performance
- P1dB = 17.5dBm @ 3.5GHz
- P1dB = 15dBm @ 5.9GHz
- IP3 = 30dBm @ 3.5GHz
- IP3 = 27dBm @ 5.9GHz
- Power up/down control < 1μs
- Active Bias controlled
- Robust Class 1C ESD rating

Applications

- Driver stage for 802.11a Access Points
- Wimax 802.16 Driver stage
- Low Power 5.8GHz ISM Output stage
- Fixed Wireless, UNII driver stage

Pin Out Description

Pin #	Function	Description
1	RFIN / VPC	RF input pin and power up down control. Supply VPC = 3.3V thru a 4.7kOhm resistor to this pin. For more gain (-0.3dB), a 5.6nH inductor can also be used in place of the resistor. If an inductor is used, move the 4.7k resistor towards the DC supply, but still in series with pin1. A minimum 1k series resistance is required on this pin from the DC supply. VPC less than 2V shuts off the amplifier.
2,5,6	Ground	Put GND vias as close as possible to these pins. It is recommended to use the via pattern in out eval board layout and recommended land pattern
3	VCC	This provides Vcc to the active bias circuit and supplies the Vcc1 collector voltage of the first stage. This pin needs to be bypassed with capacitors as close as possible to the pin. Two 0402 100pF capacitors are recommended in parallel to lower the inductance to GND thru the caps.
4	RFOUT	Rf output for the amplifier and Vcc2 for the second stage.

Simplified Device Schematic

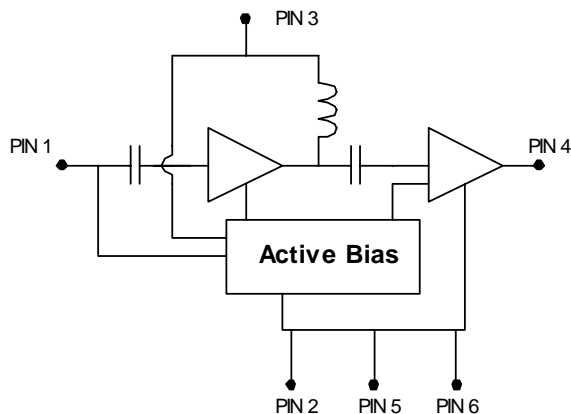

Absolute Maximum Ratings

Parameters	Value	Unit
ESD Rating (HBM)	1000	V
Total Device Current (I)	80	mA
Device Voltage (Pins 1 and 3)	4	V
Device Voltage (Pin 4)	5.5	V
Power Dissipation	0.40	W
Operating Lead Temperature (T _L)	-40 to +85	°C
RF Input Power	15	dBm
Storage Temperature Range	-40 to +150	°C
Operating Junction Temperature (T _J)	+150	°C

Operation of this device beyond any one of these limits may cause permanent damage. For reliable continuous operation the device voltage and current must not exceed the maximum operating values specified in the table on page one.

Bias conditions should also satisfy the following expression:

$$I_D V_D < (T_J - T_L) / R_{TH} \text{ j-1}$$



Caution: ESD Sensitive

Appropriate precaution in handling, packaging and testing devices must be observed.

5.1-5.9 GHz Evaluation Board Data (Vcc=VBias = 3.3V, Iq = 52mA)

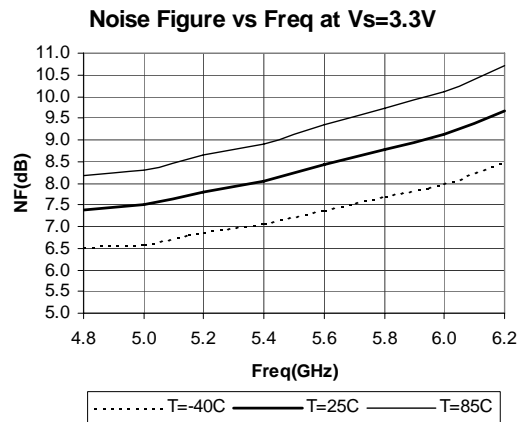
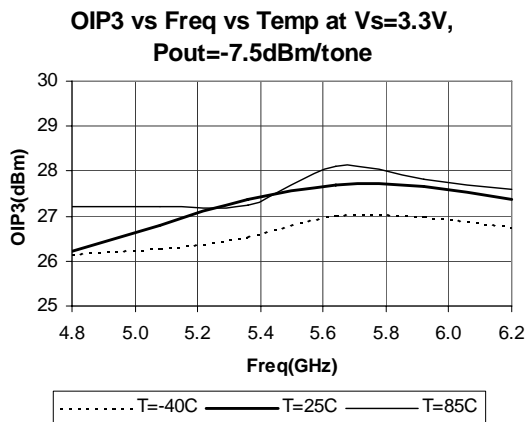
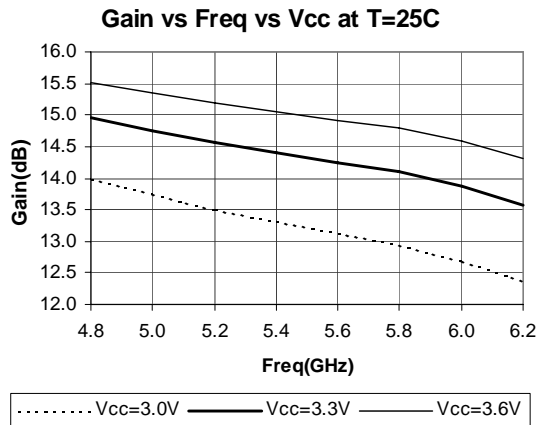
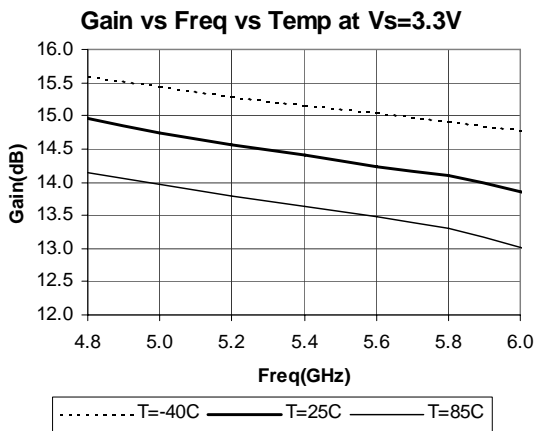
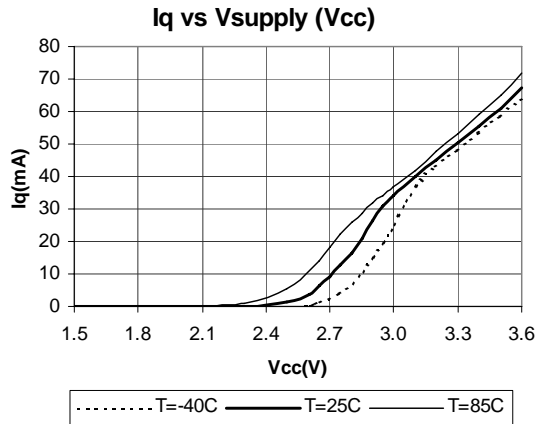
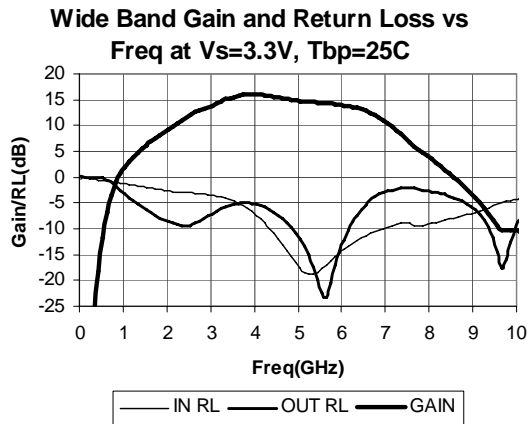

4.9 - 5.9 GHz 802.11a Error Vector Magnitude Data (source EVM = 0.7%)

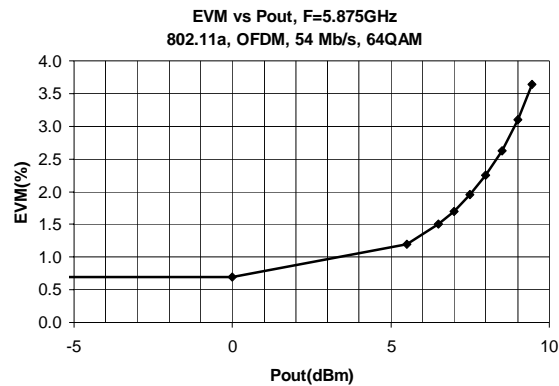
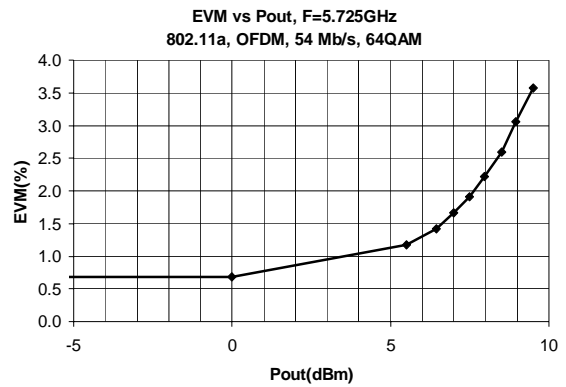
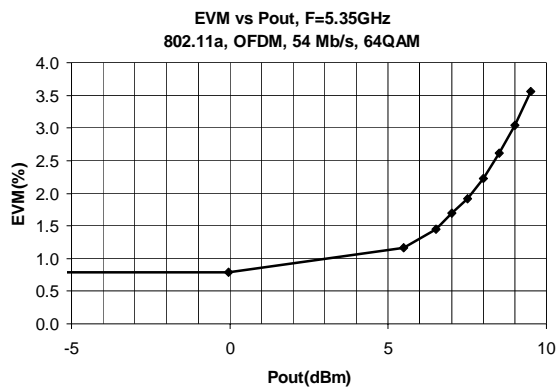
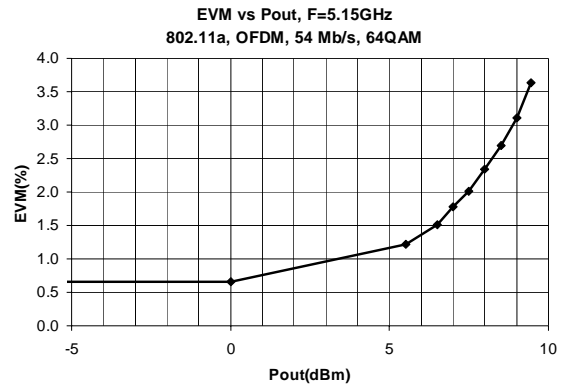
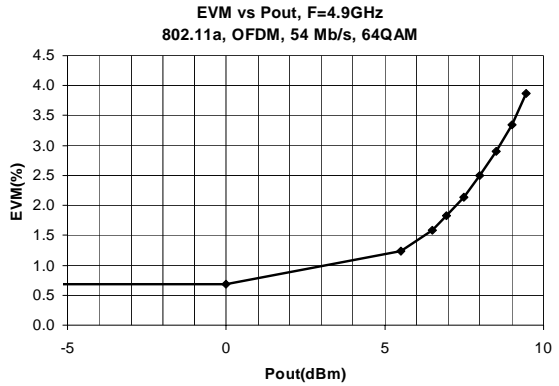

5.1 - 5.9 GHz Evaluation Board Schematic for 3.3V

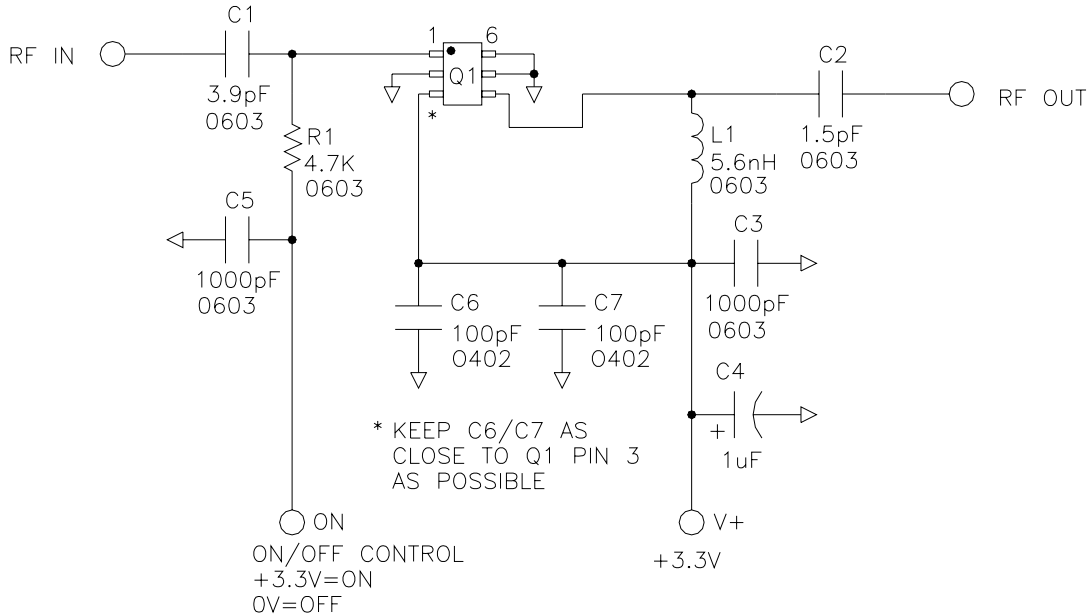

5.1 - 5.9 GHz Evaluation Board - Board material GETEK, 21mil thick, Dk=4.2, 2 oz. copper

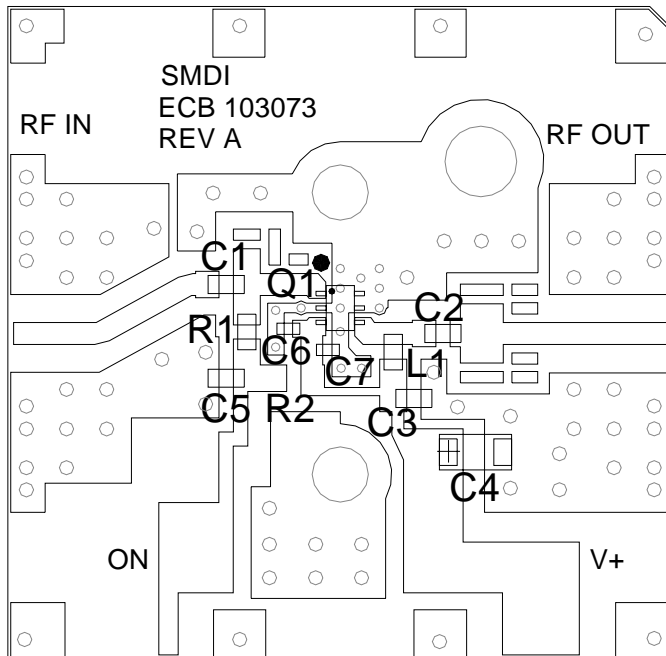

DESIGNATOR	DESCRIPTION
Q1	STA-5063
R1	4.7K OHM, 0603
C1	3.9pF CAP, 0603
C2	1.5pF CAP, 0603
C3	1000pF CAP, 0603
C4	1uF 16V TANTALUM CAP
C5	1000pF CAP, 0603
C6	100pF CAP, 0402
C7	100pF CAP, 0402
L1	5.6nH INDUCTOR, 0603

3.3-3.8 GHz Evaluation Board Data (Vcc=V_{BIAS} = 3.3V, I_q = 52mA)

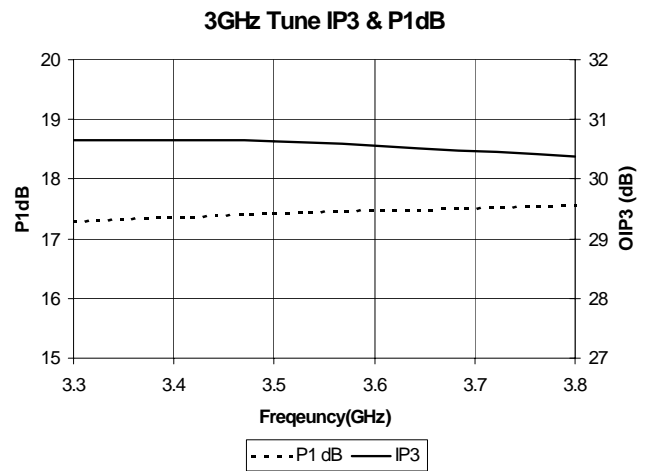
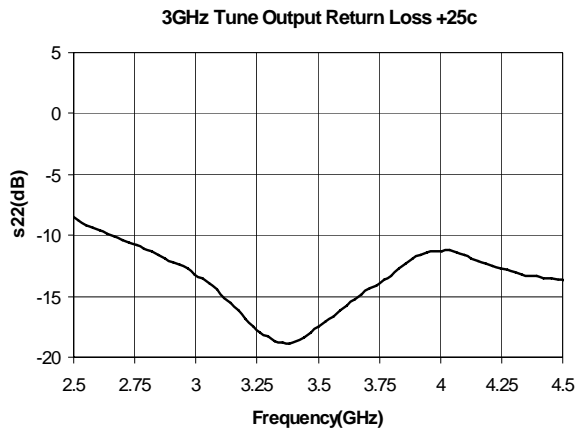
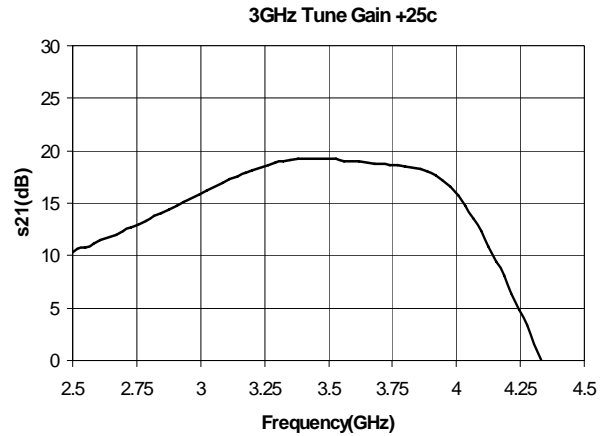
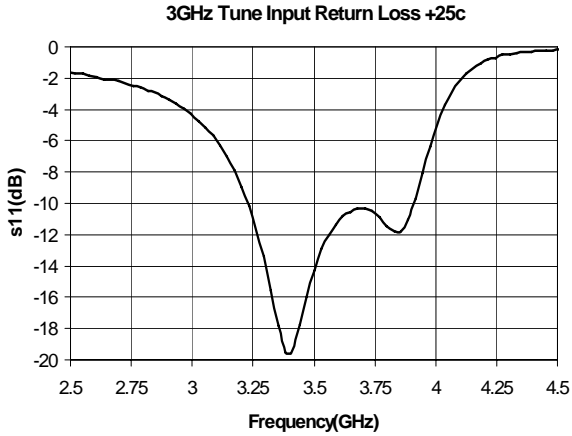

3.3 - 3.8 GHz Evaluation Board Schematic for 3.3V

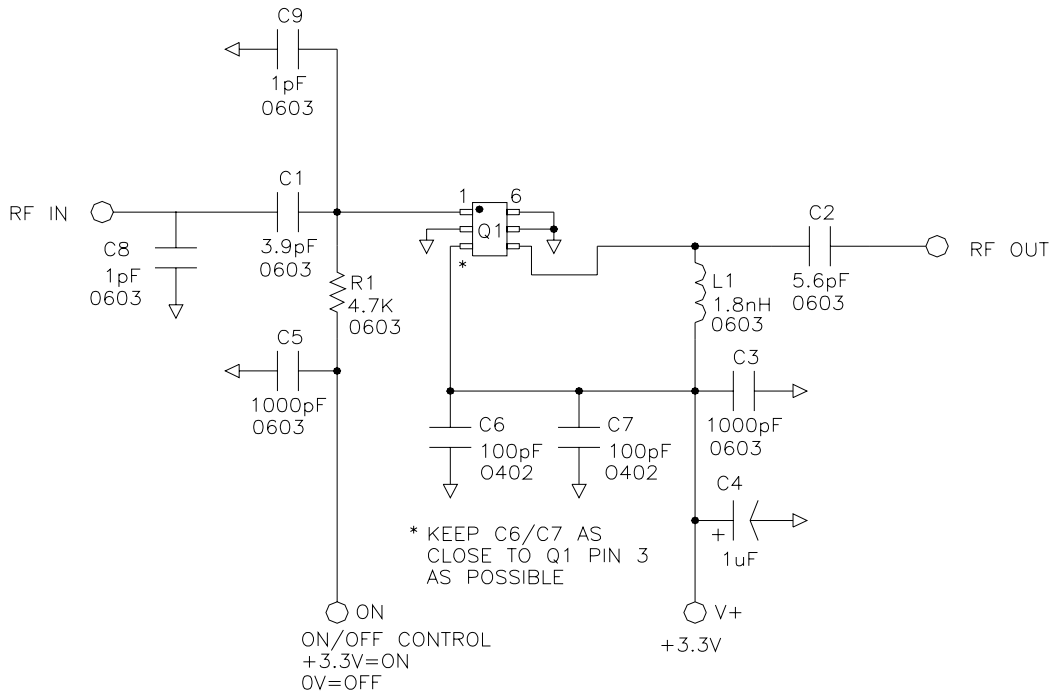

3.3 - 3.8 GHz Evaluation Board - Board material GETEK, 21mil thick, Dk=4.2, 2 oz. copper

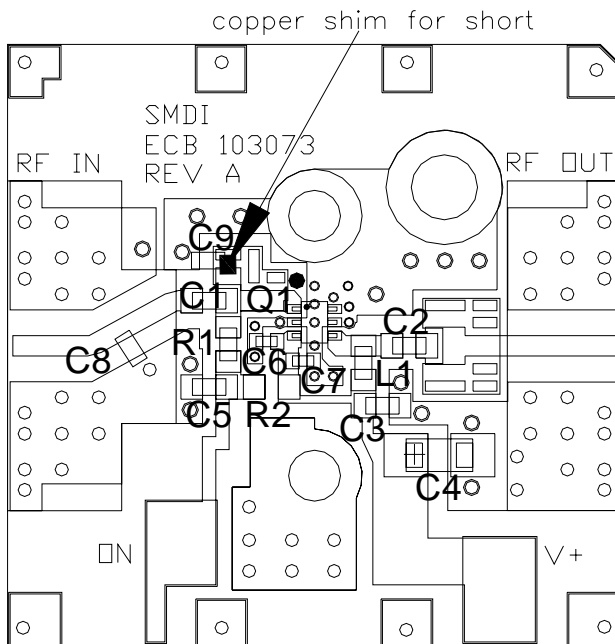

DESG	DESCRIPTION
Q1	STA-5063
R1	4.7K OHM, 0603
R2	NOT INSTALLED
C1	3.9PF, 0603
C2	5.6PF, 0603
C3	1000PF, 0603
C4	1UF, 16V
C5	1000PF, 0603
C6	100PF, 0402
C7	100PF, 0402
C8,C9	1.0pF , 0603
L1	1.8nH INDUCTOR, 0603

STA-5063Z 3.3-6.2GHz 15dBm Amplifier

Part Marking

The part will be symbolized with an "T50Z" marking designator on the top surface of the package.

Part Number Ordering Information

Part Number	Reel Size	Devices/Reel
STA-5063Z	7in	3000

Package Outline Drawing

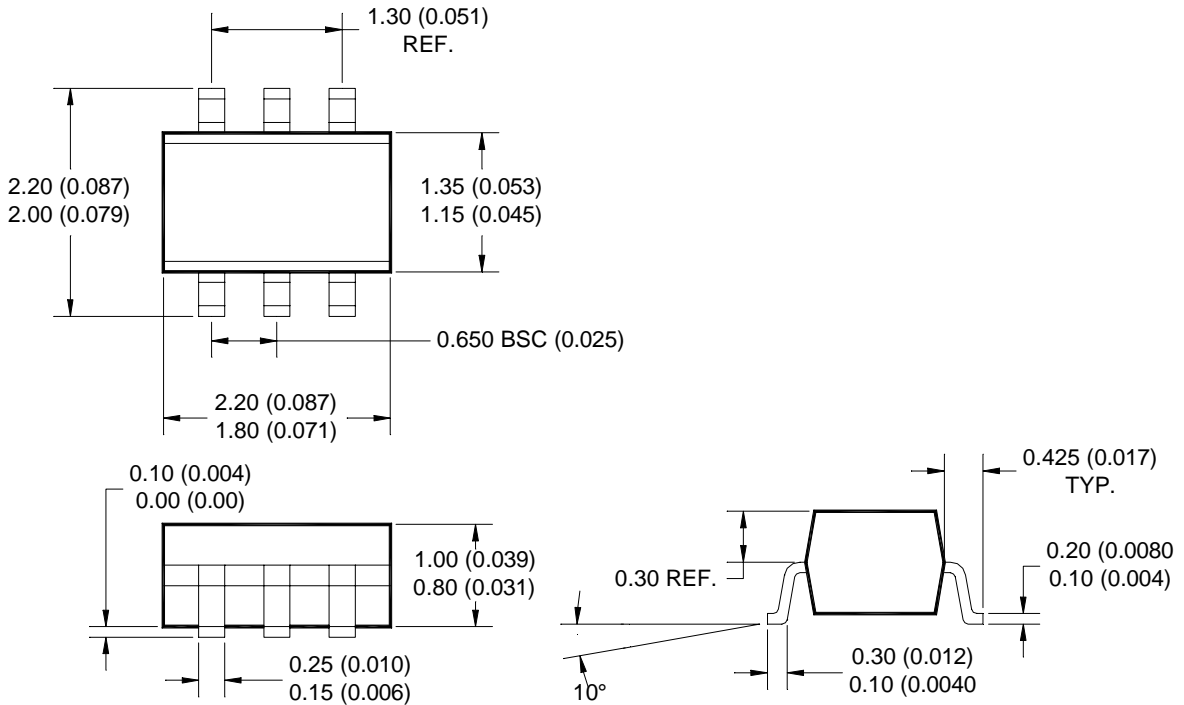

Recommended Land Pattern:

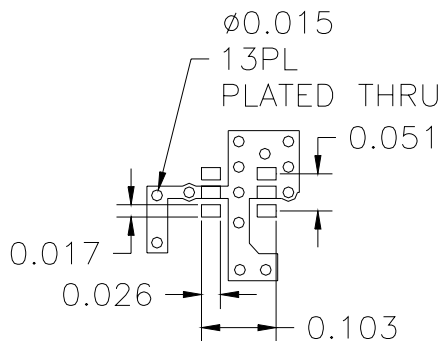

DIMENSIONS IN INCHES

Part Marking:

