

Features

- Usable bandwidth 25 MHz
- Low loss
- High Attenuation
- Single-ended operation
- No impedance matching required for operation at 50 Ω
- Ceramic Surface Mount Package (SMP)
- Hermetic
- **RoHS** compliant (2002/95/EC), **Pb-free** 

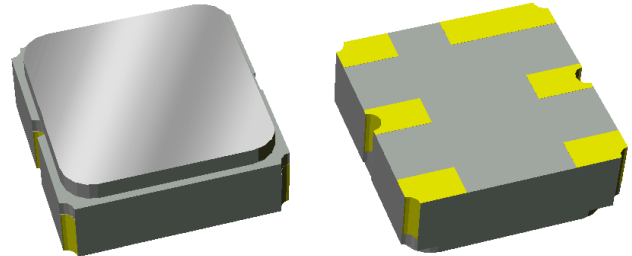

Package

Surface Mount 3.00 x 3.00 x 1.22 mm
SMP-12A

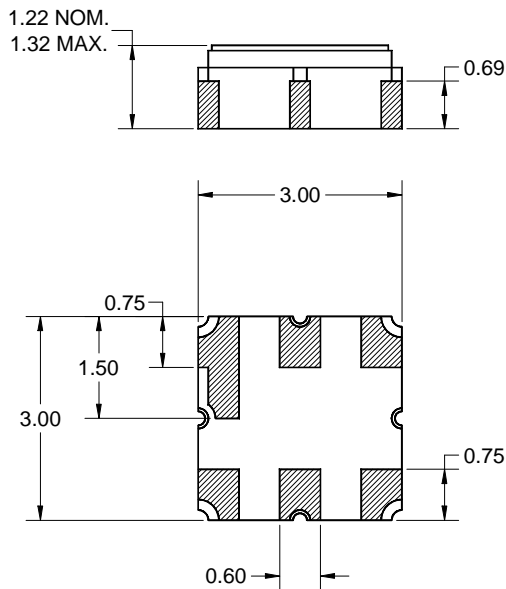

Pin Configuration

Bottom View

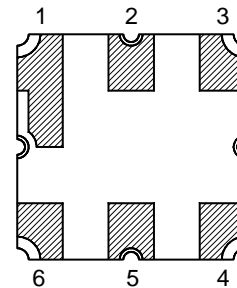

Single-ended Configuration

Pin No.	Description
2	Input
5	Output
1,3,4,6	Case Ground

Dimensions shown are nominal in millimeters
All tolerances are ± 0.15 mm except overall
length and width ± 0.10 mm

Body: Al_2O_3 ceramic
Lid: Kovar, Ni plated
Terminations: Au plating 0.5 - 1.0 μ m,
over a 2 - 6 μ m Ni plating

Electrical Specifications ⁽¹⁾

Operating Temperature Range: ⁽²⁾ -30 to +85 °C

Parameter ⁽³⁾	Minimum	Typical ⁽⁴⁾	Maximum	Unit
Center Frequency	-	836.5	-	MHz
Maximum Insertion Loss 824 - 849 MHz	-	1.2	2.0	dB
Amplitude Variation ⁽⁵⁾ 824 - 849 MHz	-	0.3	1.5	dB p-p
Amplitude Ripple ⁽⁶⁾ 824 - 849 MHz	-	0.18	0.8	dB p-p
Stop Band Attenuation ⁽⁷⁾				
180 - 220 MHz	30	46	-	dB
409 - 635 MHz	30	40	-	dB
869 - 894 MHz	10	20	-	dB
928 - 953 MHz	25	31	-	dB
1136 - 1161 MHz	20	31	-	dB
1240 - 1265 MHz	40	55	-	dB
1440 - 1692 MHz	30	52	-	dB
1853 - 2110 MHz	35	41	-	dB
2111 - 2325 MHz	30	41	-	dB
2885 - 3382 MHz	13	20	-	dB
3917 - 4439 MHz	10	19	-	dB
4949 - 5496 MHz	5	11	-	dB
Input/Output VSWR 824 - 849 MHz	-	1.68	2.0	-
Phase Ripple 824 - 849 MHz	-	9.7	30	deg p-p
Group Delay Ripple 824 - 849 MHz	-	13	30	ns p-p
Absolute Delay 824 - 849 MHz	-	21	75	ns
RF Power Handling ⁽⁸⁾	-	-	22	dBm
Load /Source Impedance ⁽⁹⁾	-	50	-	Ω

Notes:

1. All specifications are based on the TriQuint test circuit shown on page 4
2. In production, devices will be tested at room temperature to a guardbanded specification to ensure electrical compliance over temperature
3. Electrical margin has been built into the design to account for the variations due to temperature drift and manufacturing tolerances
4. Typical values are based on average measurements at room temperature
5. Describes the total variation over the defined frequency range
6. This is defined as the worst difference between a peak and adjacent valley
7. Stop Band Attenuation is relative to Pass Band Loss (not absolute value)
8. Power handling is targeted for an applied CW modulated RF signal at 55 °C for 125 hours
9. This is the optimum impedance in order to achieve the performance shown

Typical Performance (at room temperature)

Frequency Response

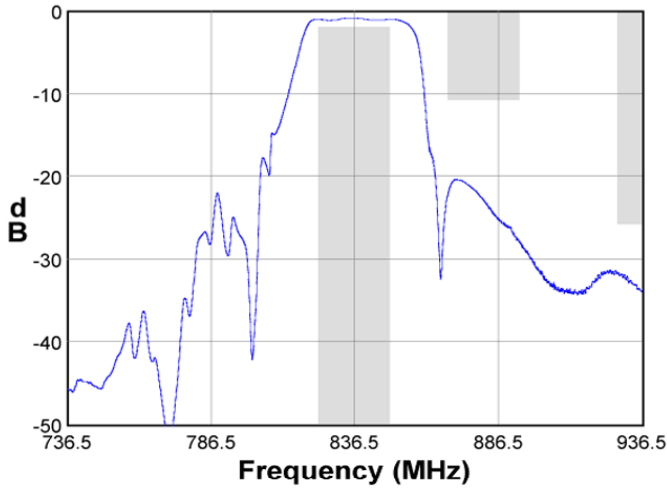

Passband Response

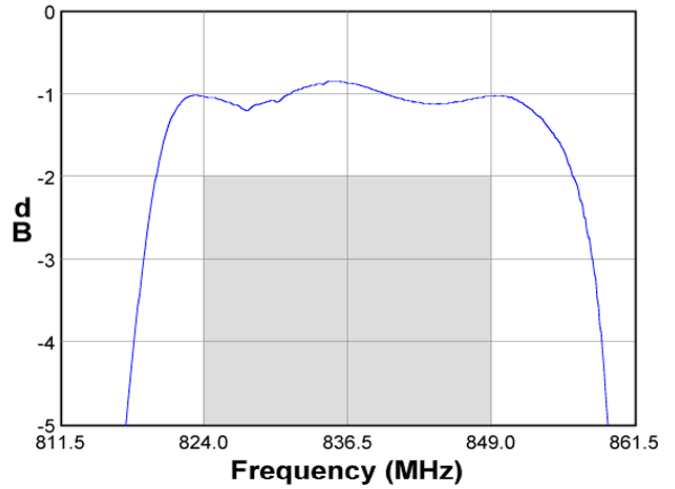

Wideband Response

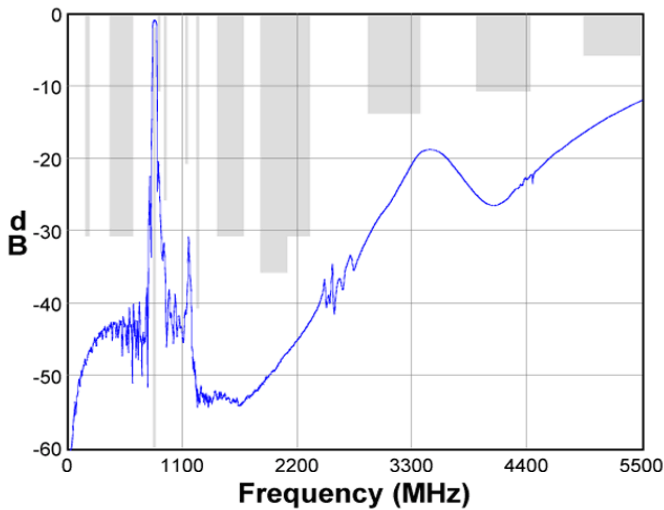

Phase \ Group Delay

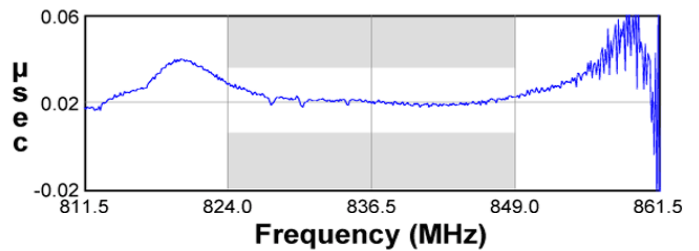
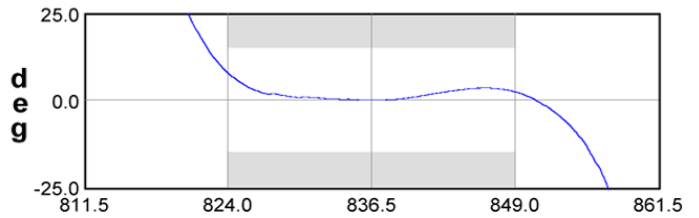

Input Smith Chart

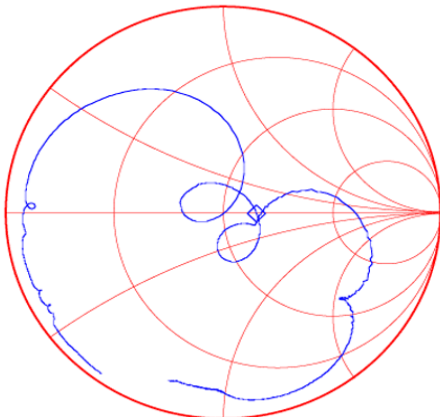

Output Smith Chart

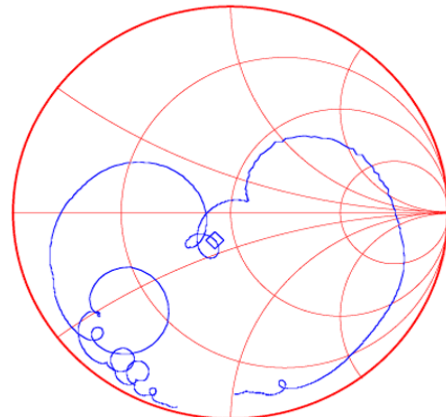

Matching Schematics

Actual matching values may vary due to PCB layout and parasitics

50 Ω
Single-ended
Input
No Matching Required

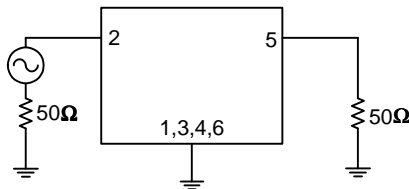

50 Ω
Single-ended
Output
No Matching Required

Marking

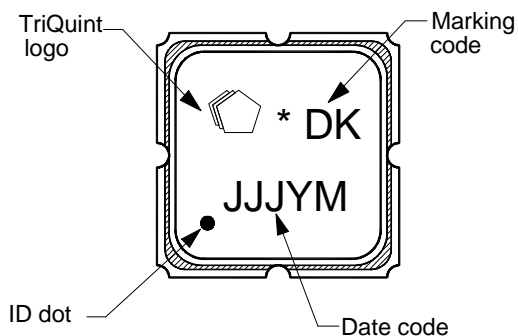

The date code consists of: day of the current year (Julian, 3 digits), last digit of the year (1 digit) and hour (2 digits)

PCB Footprint

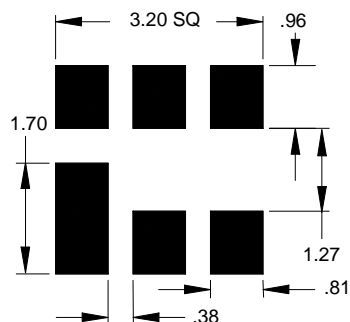

This footprint represents a recommendation only
Dimensions shown are nominal in millimeters

Tape and Reel

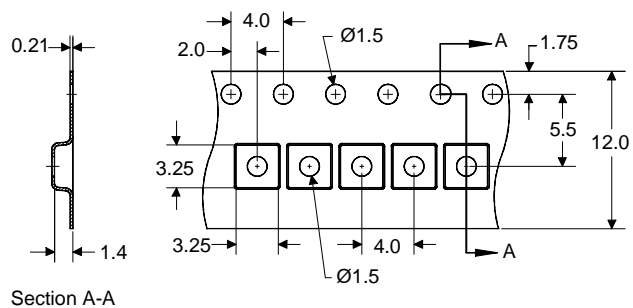
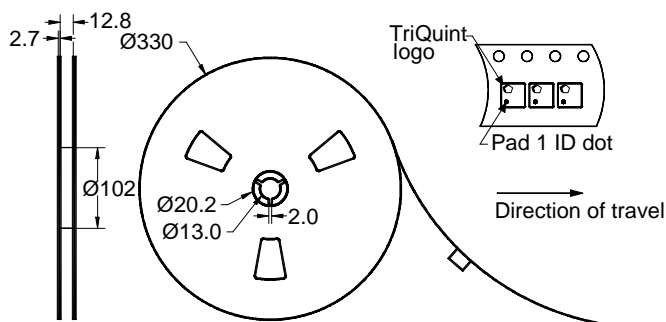

Dimensions shown are nominal in millimeters
Packaging quantity: 5000 units/reel

Maximum Ratings

Parameter	Symbol	Minimum	Maximum	Unit
Operating Temperature Range	T	-30	+85	°C
Storage Temperature Range	T _{stg}	-40	+85	°C

Important Notes

Warnings

- Electrostatic Sensitive Device (ESD) 
- Avoid ultrasonic exposure

RoHS Compliance

- This product complies with EU directive 2002/95/EC (RoHS) 

Solderability

- Compatible with JESD22-B102, Pb-free process, 260C peak reflow temperature ([see soldering profile](#))

Links to Additional Technical Information

[PCB Layout Tips](#)

[Qualification Flowchart](#)

[Soldering Profile](#)

[S-Parameters](#)

[RoHS Information](#)

[Other Technical Information](#)

TriQuint's liability is limited only to the Surface Acoustic Wave (SAW) component(s) described in this data sheet. TriQuint does not accept any liability for applications, processes, circuits or assemblies, which are implemented using any TriQuint component described in this data sheet.

Contact Information

TriQuint 
SEMICONDUCTOR

PO Box 609501
Orlando, FL 32860-9501
USA

Phone: +1 (407) 886-8860
Fax: +1 (407) 886-7061
Email: info-product@tqs.com
Web: www.triquint.com

Or contact one of our worldwide
Network of [sales offices](#),
[Representatives or distributors](#)