

RFMD®

Compact L- and S-Band GaN High Power Amplifiers

Dave Aichele, David W. Runton, Zoran Anusic, and Eric Schonthal

Key Concepts Discussed:

- Advantages and disadvantages of competing power amplifier technologies for radar applications.
- GaN power amplifiers are shaping the future of radar.
- Specific GaN solutions in production and proposed.

Contents

List of Figures.....	3
Introduction	4
Advancements in Radars	4
Industry Standard Power Amplifiers	4
VED Amplifiers.....	4
GaAs Amplifiers.....	5
Si Amplifiers	5
The Wave of the Future: GaN Amplifiers	6
RFMD Focuses GaN for Radar Applications	6
RF3928: 300W at S-Band	7
RFHA1020: 350W at L-Band	8
RFHA1023: 250W at L-Band	8
Summary	8
Appendix.....	9

List of Figures

Figure 1. Long Range Surveillance L-Band Phase Array Radar 4

Figure 2. Radar Amplifier Technology Adoption Projections 5

Figure 3. Compact S-Band GaN HPA 6

Figure 4. RF3928 RF Performance from 2.7 GHz to 3.5GHz 7

Figure 5. RFHA1020 RF Performance from 1200MHz to 1400MHz 7

Figure 6. RFHA1023 RF Performance from 1200MHz to 1400MHz 8

Figure 7. HPA Design Topology 9

Figure 8. GaN Model Source Pull, Load Pull 9

Figure 9. Design NLM Simulation 10

Figure 10. Compact L-Band GaN HPA 10

Figure 11. Pulsed RF Measurements and Affects of Pulse Width and Duty Cycle 11

Figure 12. RFMD’s MicroShield Integrated RF Shielding Technology 12

Introduction

Civilian and military radar systems rely on amplifiers to deliver pulsed and continuous wave power ranging from mere watts, to hundreds of kilowatts for microwave and millimeter frequencies. Radar use varies greatly because it can identify the range, altitude, direction, or speed of both moving and fixed objects such as ships, spacecraft, guided missiles, motor vehicles, terrain, and weather. Civilian uses include meteorological precipitation monitoring, radar astronomy, ground-penetrating geological observation, and high-resolution imaging. In military applications, radar is used in ground-penetrating, ground/air surveillance, target tracking, rendezvous systems, air-defense systems, antimissile systems, and fire control.

Figure 1. Long Range Surveillance L-Band Phase Array Radar



Some uses of radar cross over the civilian/military divide. In the air, radar is used for controlling air traffic, anticollision systems, altimetry, and flight-control. On the sea, nautical radar is used to locate landmarks and other ships and for ocean-surveillance systems. In all cases, as these radar technologies and their requirements advance, designers are seeking out next generation amplifiers that offer advantages in power, bandwidth, and efficiency over conventional technology.

Advancements in Radars

Manufacturers continue to make advancements to radar systems to meet the requirements of their customers and their environments and conditions. Several recent advancements include:

1. **Sensitivity:**
Sensitivity is the essence of radar. Systems demonstrating improved detect and monitor capabilities, capturing small, previously indistinguishable objects, are replacing older technology.
2. **Electronically Scanned Arrays:**
Mechanically scanned antennas are being supplanted with electronically driven antennas which demonstrate improvements in performance and reliability.
3. **Image enhancement:**
Advancements in computer processing and transmit/receive technologies allow newer radar systems to generate higher resolution images.
4. **Energy efficiency and increased power:**
Reducing size and weight of complex radar systems are direct results of higher efficiency and power. Smaller size and weight are critical to increasing possible civilian and military radar applications where they were not feasible before. These advancements push radar manufacturers and component suppliers to continue driving incumbent amplifier technology towards power and efficiency.

Industry Standard Power Amplifiers

Current radar technology relies on conventional Vacuum Electron Devices (VEDs), Gallium Arsenide (GaAs) and Silicon (Si) solid state amplifiers to deliver power. Most military and civilian radar systems operate in the following microwave and millimeter frequencies: L-band (1GHz to 2GHz), S-band (2GHz to 4GHz), C-band (4GHz to 8GHz), X-band (8GHz to 12GHz), ku (12GHz to 18GHz) and Ka-band (26.5GHz to 40GHz). Power requirements vary from single-digit watts to tens of kilowatts depending on the amplifier used in the system. Below, technologies providing current amplifier solutions for radar systems are explained.

VED Amplifiers

VEDs consist of Traveling Wave Tubes (TWTs), Klystrons, Magnetrons, Gyrotrons, and Cross Field Amplifiers (CFA). VEDs are capable of working from the MHz range up to hundreds of GHz and vary in power from watts to hundreds of kilowatts. VED technology is 70 years-old, however, and VEDs are complex to manufacture requiring unique materials and skill sets. VED market share is susceptible to next generation technologies that offer comparable power levels at target frequencies with robust solid state reliability.

GaAs Amplifiers

GaAs amplifiers are used as pre-drivers, drivers, and final stage amplifiers for radar systems that require high efficiency while operating in microwave and millimeter frequencies. GaAs amplifiers operate in the 5V to 28V range. Power density limitations require either combining these devices, or excluding them from use in higher power radar applications where space limitations prohibit power combining. Advancements in alternative semiconductor technology for increased bandwidth, power, and efficiency lure radar manufacturers away from GaAs amplifiers.

Si Amplifiers

Silicon amplifiers typically consist of silicon bipolar and Laterally Diffused Metal Oxide Semiconductor (LDMOS) technologies. These technologies are best known to operate at 28V, with new improvements up to 50V. This technology works well in VHF and UHF frequency ranges, but can also work up to 3.5GHz. Packaged modules using multiple die can offer power levels up to 1000W at 1GHz, but typical power levels are less than 200W. The intrinsic parasitic capacitance characteristics in this technology limit the bandwidth performance and power capabilities. This inherently limits potential improvements to efficiency and power handling.

Figure 2. Radar Amplifier Technology Adoption Projections

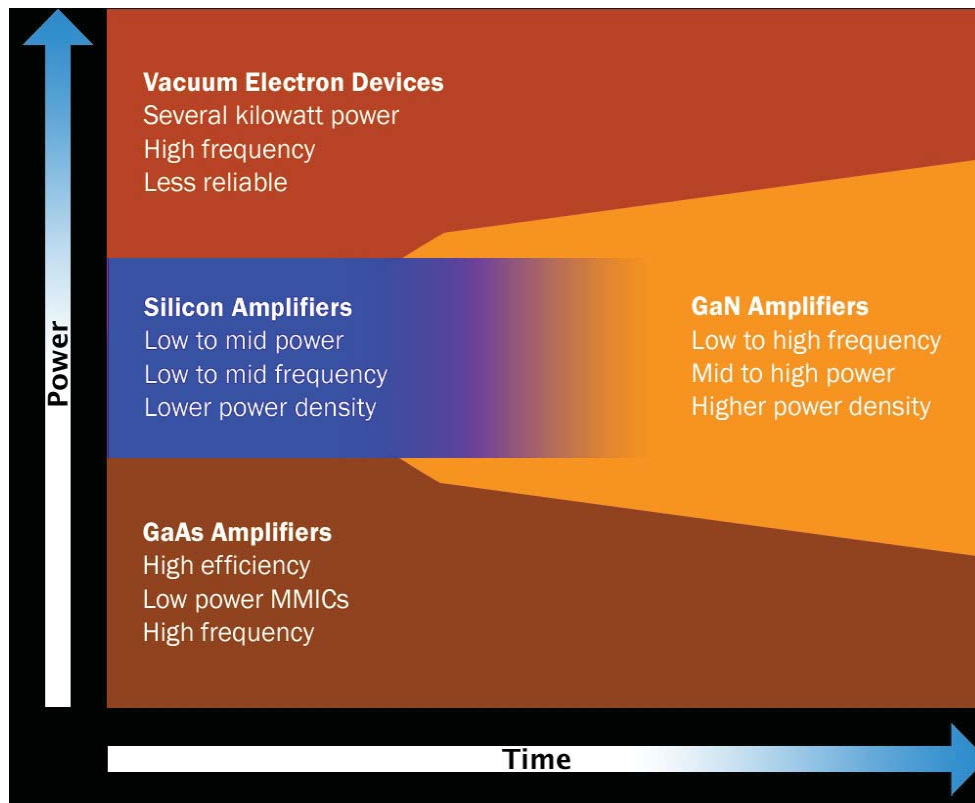

The Wave of the Future: GaN Amplifiers

Gallium Nitride (GaN) amplifiers are deployed in military radar systems where design, manufacture, and adoption rates are increasing each year. For applications operating in frequency bands less than 6GHz, radar manufacturers recognize that this wide-band gap technology offers significant advantages over existing Si and VED amplifiers. Advantages include higher voltage and broadband performance with high drain efficiency. There is increased GaN manufacturing activity in the U.S. and Japan toward higher frequency radar applications, (those greater than 10GHz), with emphasis on improvements in bandwidth, power output, and efficiency. These higher frequency GaN solutions are encroaching on entrenched GaAs and VED design slots and market share.

RFMD Focuses GaN for Radar Applications

GaN is relatively new to the market. Several established RF companies have invested considerable resources to develop a robust, reliable GaN semiconductor technology targeting multiple markets. The pulsed and CW performance from GaN radar systems are ideally suited for both civilian and military applications. First generation RFMD GaN technology was released as a 50V process with power density greater than 5W/mm and respectable

power gain performance up to 6GHz. RFMD has developed a family of high power, high efficiency, broadband amplifiers that are positioned for L-band, S-band, and C-band radar applications.

Figure 3 shows a typical RFMD solution including the partially matched power transistor, bias network, and on-circuit-board matching elements. The package is a hermetically sealed bolt-down package for optimum thermal contact. The package houses the GaN transistor die, splitting and combining networks, matching, and stabilization circuitry.

The impedance at the package pin for the device is typically 15Ω to 25Ω. This higher impedance allows the circuit board matching elements to remain compact as shown in Figure 3. The wide-dimension, low-impedance matching traces, typical in silicon-based solutions, which take up significant amounts of circuit board area, are not required. For radar applications requiring several devices combined in parallel to achieve multi-kilowatt amplifiers, the cost benefits of module size reduction alone represent a significant advantage. Indeed, equivalent silicon-based solutions may have a footprint 10 times larger.

Figure 3. Compact S-Band GaN HPA



RF3928: 300W at S-Band

RFMD’s RF3928 was designed for operation from 3GHz to 3.5GHz and provides over 300W of pulsed peak power, with peak gain greater than 9dB and peak drain efficiency of 46% to 52% over that frequency range.

Previously RFMD has shown that this amplifier topology is very flexible and can achieve wide bandwidth (25% bandwidth) while providing high-output power and efficient operation. Figure 4 presents board tuned

performance for the RF3928 covering the full 2.7GHz to 3.5GHz band. This broadband performance represents fixed circuit board tuning with no adjustments to bias or tuning component changes.

All measurements were taken under pulsed conditions using a 100µsec pulse at 10% duty cycle. Power drop across the pulse width is typically 0.2dB indicating that the thermal properties of the GaN device and package are not limiting performance.

Figure 4. RF3928 RF Performance from 2.7GHz to 3.5GHz

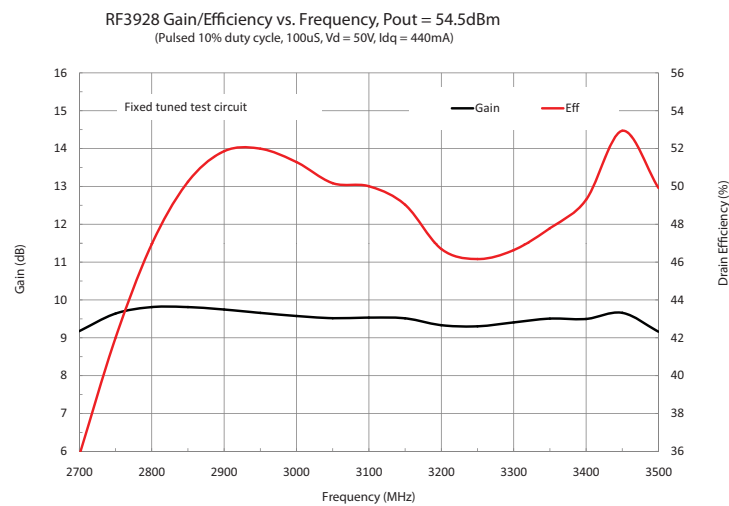
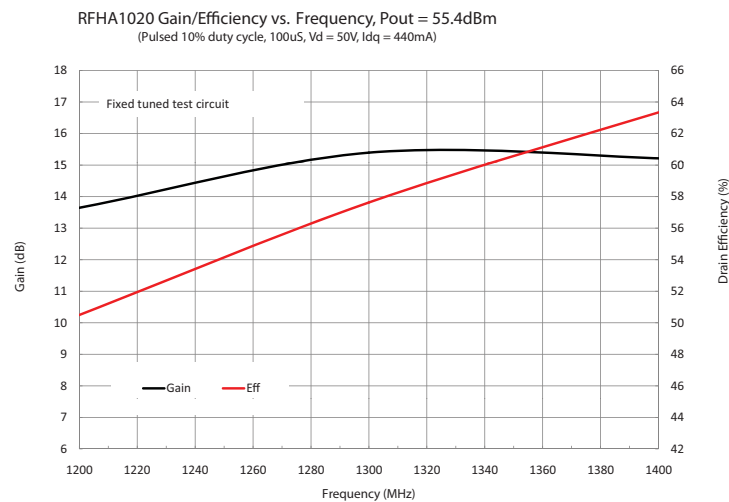

Figure 5. RFHA1020 RF Performance from 1200MHz to 1400MHz



RFHA1020: 350W at L-Band

RFMD has developed the RFHA1020 to provide high power at L-band frequencies. This part uses the same circuit topology and package as the RF3928, but provides high power performance from 0.9GHz to 1.4GHz, optimized from 1.2GHz to 1.4GHz (performance evaluation is included in Figure 5).

RFHA1020 provides high-output power from 0.9GHz to 1.4GHz and output power greater than 300W over the entire frequency band, while optimized output power of 350W is achieved from 1.2GHz to 1.4GHz. Power gain ranges from 13.6dB to 15.5dB, and peak drain efficiency ranges from 50% to 63%.

RFHA1023: 250W at L-Band

RFMD’s RFHA1023 provides a lower power output solution at L-band operating at 36V. This part incorporates in package pre-matching in a bolt down high-thermal conductivity solution.

Figure 6 provides measured data on the performance of this part under the same pulsed conditions previously discussed. The RFHA1023 achieves 250W peak output power over the same 1.2GHz to 1.4GHz, 15% bandwidth, while maintaining greater than 13dB gain at peak power. Peak drain efficiency ranges from 52% to 64% and small signal gain exceeds 14dB with power gain ranging from 13.2dB to 14.6dB at 250W output power.

Summary

RFMD has developed a portfolio of high power matched amplifier products to provide solutions for next generation military and civilian radar applications. Wide bandwidth, high output power, and high efficiency operation enable simplification of high-power radar system modules. Design using GaN devices allows for multiple bands to be covered by a single matched design, reducing size and complexity of the overall multi-kilowatt amplifier. The resulting designs allow for tighter integration through smaller system footprints and reduced cooling needs, which leads to enhanced device efficiency and lower operational costs.

Figure 6. RFHA1023 RF Performance from 1200MHz to 1400MHz

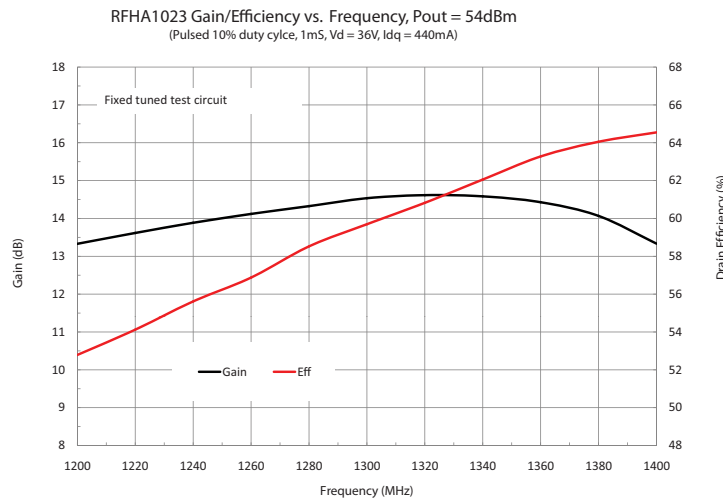

Appendix

Figure 7. HPA Design Topology

- Wilkinson combiners at input and output of devices, 50Ω impedance at the package leads
- Two stage quarter-wave impedance transformation for broader bandwidth
- High dielectric substrates for impedance transformation to present optimum load / source impedance to device
- Isolation resistors to prevent odd-mode oscillations

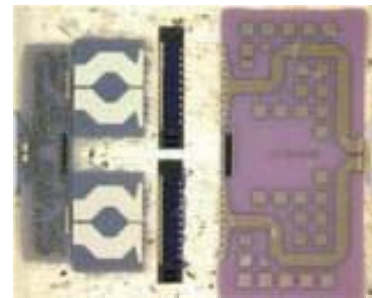
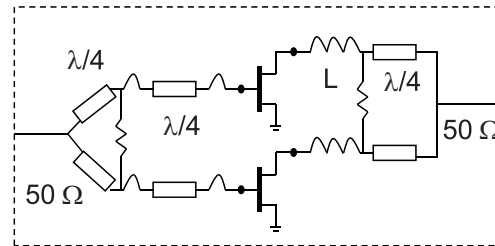
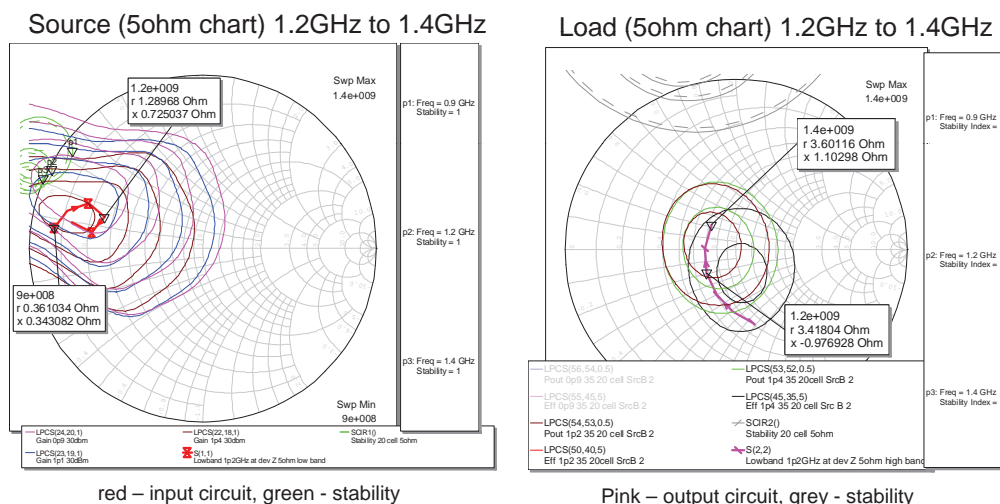

Figure 8. GaN Model Source Pull, Load Pull



- GaN Non Linear Model (NLM) used to generate source and load contours
- Source contours generated for Pin = +10dBm
- Load contours generated for Pin = +41dBm

Figure 9. Design NLM Simulation

- EM simulation used to design splitter/combiner networks
- GaN Non Linear Model (NLM) used to estimate RF performance over frequency
- Ideal bias networks (lossless, broadband) used for simulation
- NLM provides isothermal results (short pulse)

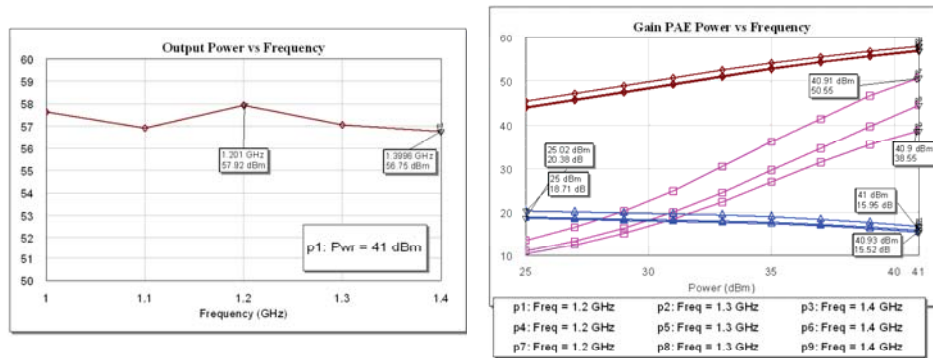
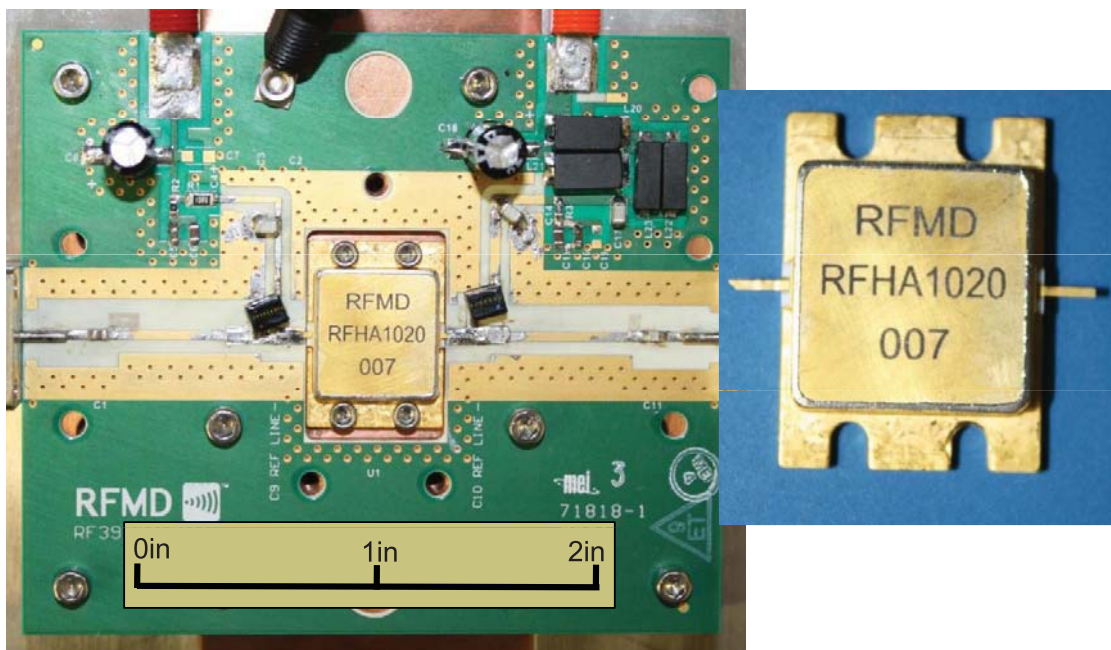
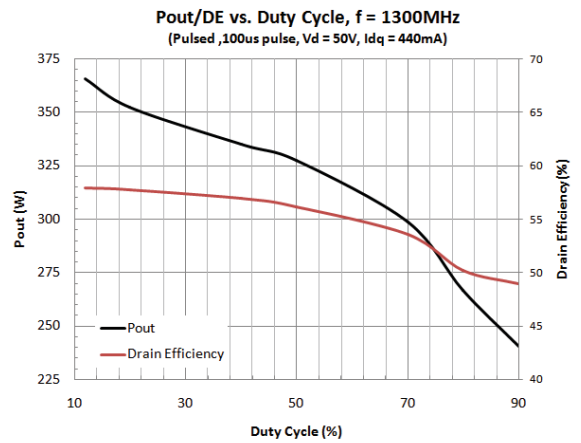
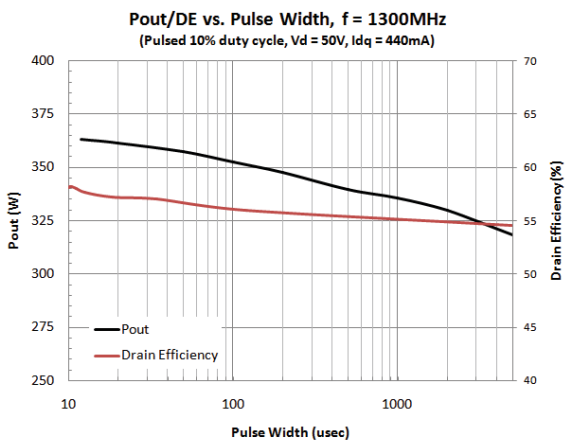
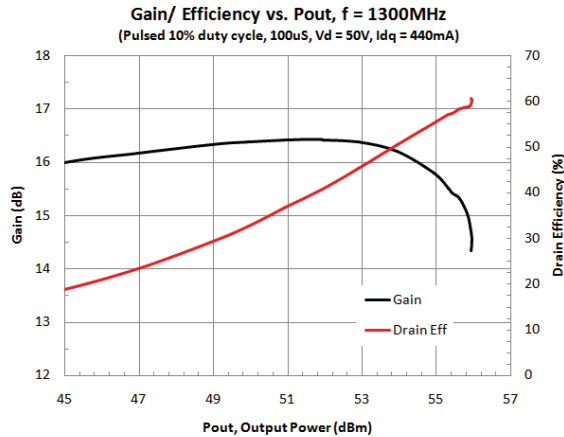

Figure 10. Compact L-Band GaN HPA



Compact application circuit for L-band 350W solution: 2" x 2"

Figure 11. Pulsed RF Measurements and Affects of Pulse Width and Duty Cycle



1.2GHz to 1.4GHz	100µsec 10% dc	1msec 10% dc	100µsec 40% dc
Peak Output Power	350W	335W	335W
Peak efficiency	58%	57%	57%
Gain @ peak power	15dB	14.8dB	14.7dB

0.4dB to 0.6dB drop in power from 100µsec pulse @ 10% duty cycle to 1msec pulse @ 20% duty cycle

100µsec pulse, 10% duty cycle

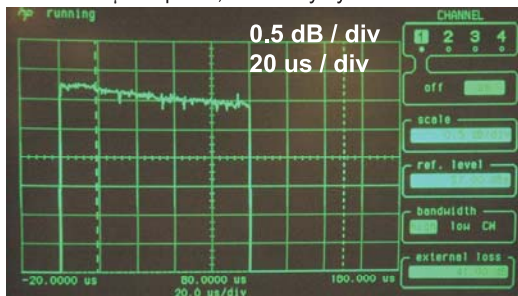

1msec pulse, 20% duty cycle

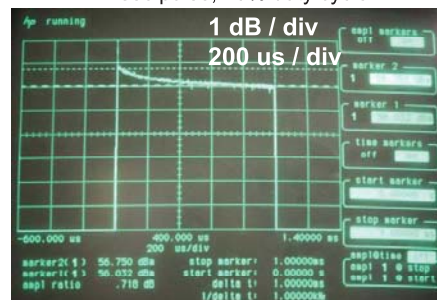

Figure 12. RFMD's MicroShield Integrated RF Shielding Technology

- Demonstrated a compact 350W L-band power amplifier
- Design completed using non linear model results exclusively
- Package matched to $25\ \Omega$ at the input and output lead
- Application real estate including bias networks and occupies a 2 inch by 2 inch area
- Optimized for 1.2GHz to 1.4GHz, but can operate with 31% bandwidth
- For long pulse widths and duty cycles 0.4dB to 0.6dB drop in peak power performance



1.2GHz to 1.4GHz (200MHz, 15% bandwidth)

- Peak Pout 350W
- Peak efficiency 52% to 64%
- Gain at peak power 13.5dB to 15.5dB
- Linear gain 14.5dB to 16.0dB