

**Measurement condition**

|                             |        |     |
|-----------------------------|--------|-----|
| Ambient temperature $T_A$ : | 23     | °C  |
| Input power level:          | 0      | dBm |
| Terminating impedance: *    |        |     |
| Input:                      | t.b.d. |     |
| Output:                     | t.b.d. |     |

**Characteristics**

## Remark:

The reference level for the relative attenuation  $a_{rel}$  of the TFS120U is the minimum of the pass band attenuation. This value is defined as the insertion loss  $a_e$ . The nominal frequency  $f_N$  is fixed at 120.0 MHz without any tolerance. The values of relative attenuation  $a_{rel}$  are guaranteed over the whole operating temperature range. The frequency shift of the filter within the operating temperature range is included in the production tolerance scheme.

| <b>D a t a</b>  |            | <b>typ. value</b> |                    | <b>tolerance / limit</b> |                      |     |
|---|------------|-------------------|--------------------|--------------------------|----------------------|-----|
| <b>Insertion loss</b>   | $a_e$      | -                 | dB                 | max.                     | 7                    | dB  |
| <b>Nominal frequency</b>  | $f_N$      | -                 |                    |                          | 120.0                | MHz |
| <b>Passband</b>   | PB         | -                 |                    |                          | $f_N \pm 0.2$        | MHz |
| <b>Passband ripple</b>  | p-p        | -                 |                    | max.                     | 1.0                  | dB  |
| <b>Relative attenuation</b>   | $a_{rel}$  |                   |                    |                          |                      |     |
| $f_N \pm 0.2$ MHz   |            | -                 | dB                 | max.                     | 1                    | dB  |
| $f_N \pm 1.1$ MHz ... $f_N \pm 20$ MHz                              |            | -                 | dB                 | min.                     | 35                   | dB  |
| <b>Group delay ripple (p-p) within PB</b>                           |            | -                 |                    | max.                     | 125                  | ns  |
| <b>Group delay ripple (p-p) within <math>f_N \pm 0.1</math> MHz</b> |            | -                 |                    | max.                     | 70                   | ns  |
| <b>Operating temperature range</b>                                  | OTR        | -                 |                    |                          | - 40 °C ... + 85 °C  |     |
| <b>Storage temperature range</b>                                    |            | -                 |                    |                          | - 55 °C ... + 125 °C |     |
| <b>Frequency inversion temperature</b>                              | $T_0$      | 25                | °C                 |                          |                      |     |
| <b>Temperature coefficient of frequency</b>                         | $TC_f$ **) | -0.036            | ppm/K <sup>2</sup> |                          |                      |     |

\*) The terminating impedances depend on parasitics and q-values of matching elements and the board used, and are to be understood as reference values only. Should there be additional questions do not hesitate to ask for an application note or contact our design team.

\*\*)  $\Delta f = TC_f (T - T_0)^2 f_N$

**Generated:**

---

**Checked / Approved:**

---

**Vectron International GmbH**  
**Potsdamer Straße 18**  
**D 14 513 TELTOW / Germany**  
**Tel: (+49) 3328 4784-0 / Fax: (+49) 3328 4784-30**  
**E-Mail: [tft@vectron.com](mailto:tft@vectron.com)**

Vectron International GmbH reserves the right to make changes to the product(s) and/or information contained herein without notice. No liability is assumed as a result of their use or application. No rights under any patent accompany the sale of any such product(s) or information.

**Filter characteristic**

t.b.d.

**Construction and pin connection**

(All dimensions in mm)

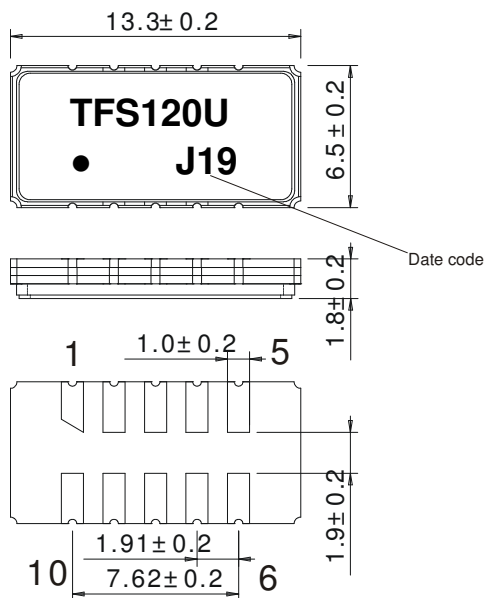

|    |        |
|----|--------|
| 1  | Ground |
| 2  | Ground |
| 3  | Ground |
| 4  | Ground |
| 5  | Output |
| 6  | Ground |
| 7  | Ground |
| 8  | Ground |
| 9  | Ground |
| 10 | Input  |

Date code: Year + week  
 J 2017  
 K 2018  
 L 2019  
 ...

**50 Ω Test circuit**

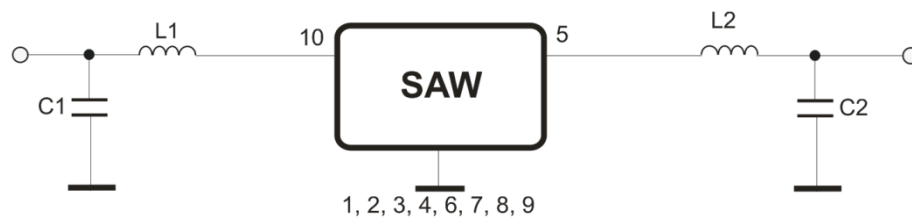

**Vectron International GmbH**  
 Potsdamer Straße 18  
 D 14 513 TELTOW / Germany  
 Tel: (+49) 3328 4784-0 / Fax: (+49) 3328 4784-30  
 E-Mail: [tft@vectron.com](mailto:tft@vectron.com)

Vectron International GmbH reserves the right to make changes to the product(s) and/or information contained herein without notice. No liability is assumed as a result of their use or application. No rights under any patent accompany the sale of any such product(s) or information.

**Stability characteristics, reliability**

After the following tests the filter shall meet the whole specification:

1. Shock: 500 g, 1 ms, half sine wave, 3 shocks each plane;  
DIN IEC 60068 T2 - 27
2. Vibration: 10 Hz to 2000 Hz, 0.35 mm or 5 g respectively, 1 octave per min, 10 cycles per plane, 3 planes; DIN IEC 60068 T2 - 6
3. Change of temperature: -55 °C to 125 °C / 15 min. each / 100 cycles  
DIN IEC 60068 part 2 – 14 Test N
4. Resistance to solder heat (reflow): reflow possible: three times max.;  
for temperature conditions refer to the attached "Air reflow temperature conditions" on page 4;
5. SAW devices are Electrostatic Discharge (ESD) sensitive devices.

This filter is RoHS compliant (2011/65/EU)

**Packing**

Tape & Reel: IEC 286 – 3, with exception of value for N and minimum bending radius;  
tape type II, embossed carrier tape with top cover tape on the upper side;

|   |             |
|---|-------------|
| max. pieces of filters per reel:                    | 1700        |
| reel of empty components at start:                  | min. 300 mm |
| reel of empty components at start including leader: | min. 500 mm |
| trailer:  | min. 300 mm |

- Tape (all dimensions in mm)**
- W : 24.00 +0.30/-0.10
  - Po : 4.00 ±0.1
  - Do : 1.50 +0.1/0
  - E : 1.75 ±0.10
  - F : 11.50 ±0.10
  - G(min) : 0.60
  - P2 : 2.00 ±0.1
  - P1 : 12.00 ±0.1
  - D1(min) : 1.50
  - Ao : 7.00 ±0.10
  - Bo : 13.80 ±0.10
  - Ct : 21.00 ±0.1
  - Ko : 2.10 ±0.10
  - t : 0.30 ±0.05

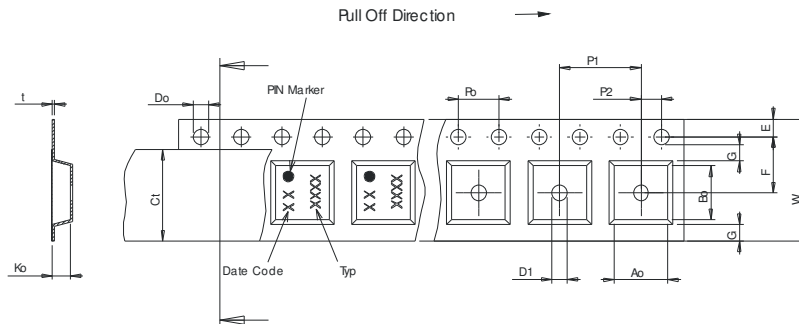

- Reel (all dimensions in mm)**
- A : 330 or 180
  - W1 : 24.4 +2/-0
  - W2(max) : 30.40
  - N(min) : 60.00
  - C : 13.0 +0.5/-0.2

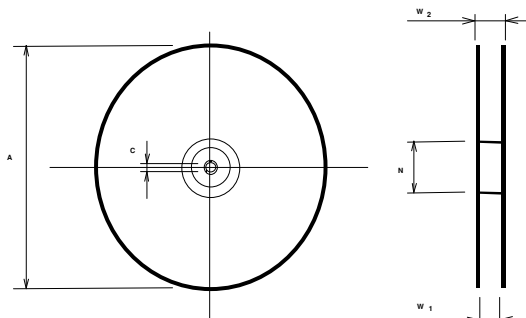

The minimum bending radius is 45 mm.

**Vectron International GmbH**  
**Potsdamer Straße 18**  
**D 14 513 TELTOW / Germany**  
**Tel: (+49) 3328 4784-0 / Fax: (+49) 3328 4784-30**  
**E-Mail: [tft@vectron.com](mailto:tft@vectron.com)**

Vectron International GmbH reserves the right to make changes to the product(s) and/or information contained herein without notice. No liability is assumed as a result of their use or application. No rights under any patent accompany the sale of any such product(s) or information.

## Air reflow temperature conditions

| Conditions                                  | Exposure                    |
|---|-----------------------------|
| Average ramp-up rate (30 °C to 217 °C)      | less than 3 °C / second     |
| > 100 °C                                    | between 300 and 600 seconds |
| > 150 °C                                    | between 240 and 500 seconds |
| > 217 °C                                    | between 30 and 150 seconds  |
| Peak temperature                            | max. 260 °C                 |
| Time within 5 °C of actual peak temperature | between 10 and 30 seconds   |
| Cool-down rate (Peak to 50 °C)              | less than 6 °C / second     |
| Time from 30 °C to Peak temperature         | no greater than 300 seconds |

Chip-mount air reflow profile

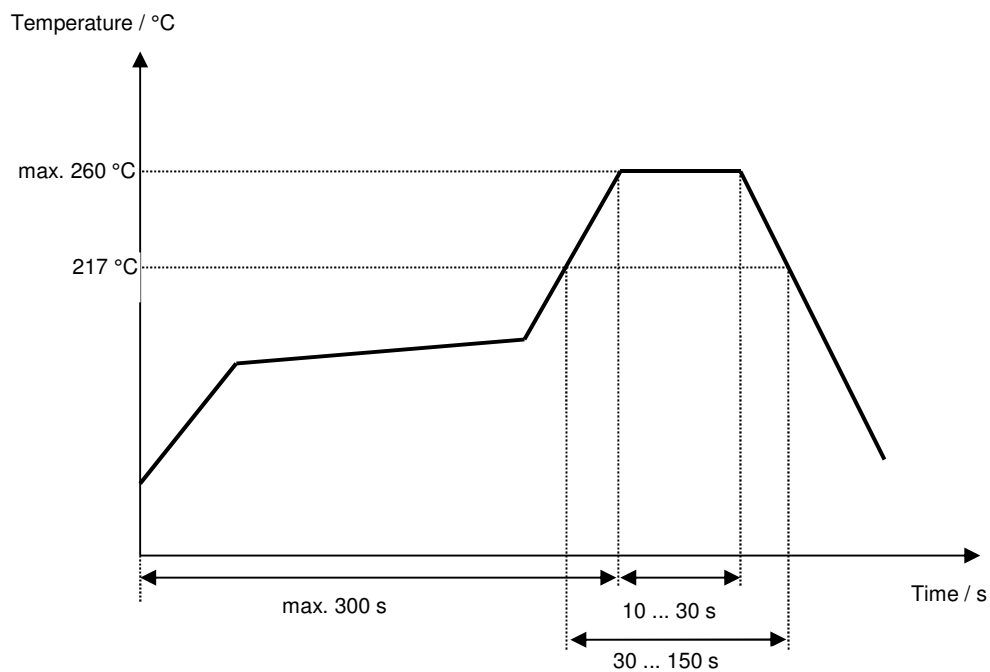

**History**

| <b>Version</b> | <b>Reason of Changes</b>                     | <b>Name</b> | <b>Date</b> |
|----------------|--|-------------|-------------|
| 1.0            | - Generation of development specification    | Bonnen      | 11.05.2017  |
| 1.1            | - Update GDR limits as per customer request. | Jaffer      | 15.05.2017  |
| 1.2            | - Add missing $T_0$ symbol to data table.    | Jaffer      | 17.05.2017  |