

Helping Customers Innovate, Improve & Grow



TX-552

Description

The TX-552 Series TCXO combines innovative manufacturing and the latest technology to provide extremely low phase noise and g-sensitivity. The assembly includes a dual crystal circuit to cancel opposing g-sensitivity vectors.

Features

- Low Phase Noise, Low g-Sensitivity
- Fully RoHS Compliant 
- Surface Mount, Low Profile
- High Shock Survival up to 20 Kg
- Frequency Range: 8 MHz to 100 MHz

Applications

- Military Portable Radios
- GPS Telemetry
- Test and Measurement Equipment

Performance Specifications

Parameter	Min	Typ	Max	Units	Condition
Frequency Stabilities¹					
vs. operating temperature range (referenced to +25°C)	-2.0 -1.0		+2.0 +1.0	ppm ppm	-40... +105°C -40... +85°C
Initial Tolerance	-1.0		+1.0	ppm	at time of shipment, nominal EFC Vs ± 5% Load ± 10% @ +40°C for 15 years
vs. supply voltage change	-0.1		+0.1	ppm	
vs. load change	-0.2		+0.2	ppm	
vs. aging / 1 year		±1		ppm	
vs. aging			4.0	ppm	
Supply Voltage (Vs)					
Supply voltage (option D)	4.75	5.0	5.25	VDC	
Supply voltage (option E)	3.135	3.3	3.465	VDC	
Current consumption			35	mA	

Performance Specifications

Parameter	Min	Typ	Max	Units	Condition
RF Output					
Subharmonics			0	dBc	F≤50 Mhz
			-20	dBc	F>50 MHz
HCMOS					
Load		15		pF	
Signal Level (Vol)			0.1*Vs	V	
Signal Level (Voh)	0.9*Vs			V	
Rise/Fall Time			5	ns	@ nominal Load and 10% to 90% of waveform
Duty cycle	40	50	60	%	@ nominal Load and @ 50% level
Clipped Sinewave (F≥ 30 MHz)					
Level		1		Vpp	with Nominal Load
Load R		10		kOhm	
Load C		10		pF	
Sinewave (F≥ 30 MHz)					
Load		50		Ohm	
Output	0	3	6	dBm	with Nominal Load
Harmonics			-20	dBc	
Frequency Tuning (EFC)					
Tuning Range (option A)	Fixed; No adjust				
Tuning Range (option B)	±5.0			ppm	
Tuning Slope	Positive				
Control Voltage Range	0.0		Vs	VDC	
Freq. control input impedance	10			kOhm	
Additional Parameters¹					
Phase Noise ³ (@ 10 MHz - no vibration)		-110		dBc/Hz	10 Hz
		-130		dBc/Hz	100 Hz
		-145		dBc/Hz	1 kHz
		-155		dBc/Hz	10 kHz
		-160		dBc/Hz	100 kHz
Phase Noise ³ (@ 40 MHz - no vibration)		-100		dBc/Hz	10 Hz
		-120		dBc/Hz	100 Hz
		-140		dBc/Hz	1 kHz
		-155		dBc/Hz	10 kHz
		-155		dBc/Hz	100 kHz
Phase Noise ³ (@ 100 MHz - no vibration)		-81		dBc/Hz	10 Hz
		-107		dBc/Hz	100 Hz
		-130		dBc/Hz	1 kHz
		-148		dBc/Hz	10 kHz
		-151		dBc/Hz	100 kHz
g-Sensitivity		0.2		ppb/g	per axis
Shock					MIL-STD-202G; Method 213B; Test Condition B
Vibration Random					MIL-STD-202G; Method 214A; Test Condition I-F
Vibration Sine					MIL-STD-202G, METHOD 204D, Test Condition A
Thermal Cycling					MIL-STD-202, METHOD 107, Test Condition A

Parameter	Min	Typ	Max	Units	Condition
Absolute Maximum Ratings					
Supply voltage (Vs)			6.0	V	Damage may occur beyond this level
Control Voltage	0		Vs	V	
Operable temperature range	-45		+105	°C	
Storage temperature range	-55		+125	°C	

Standard Shipping Method

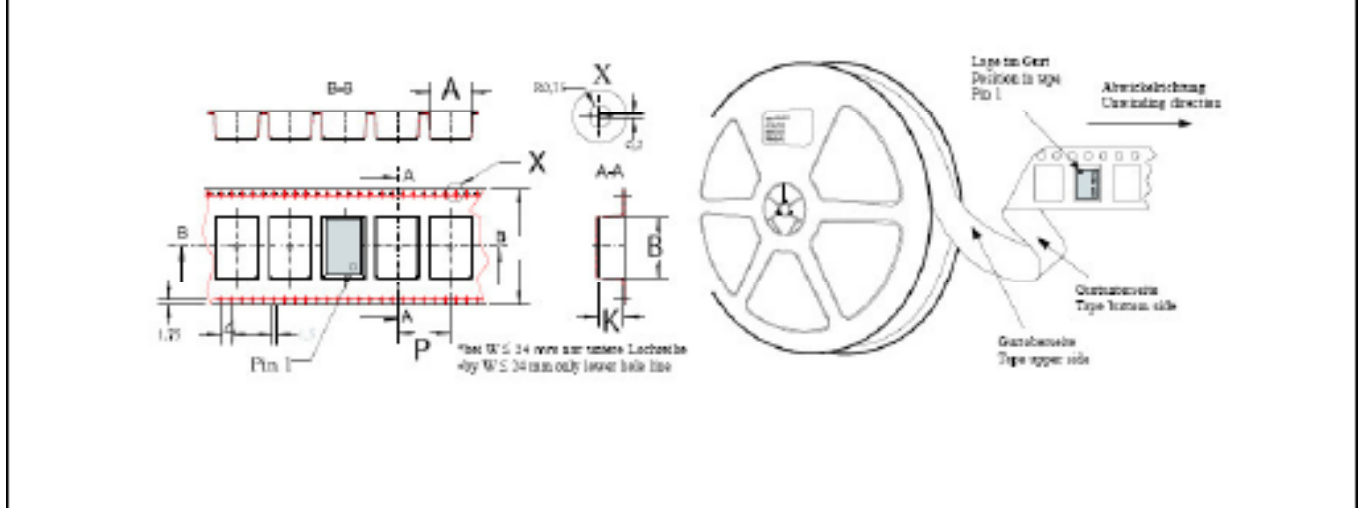

Production tolerance complying DIN IEC 286-3

Enclosure Type	Tape width W (mm)	Quantity per meter	Quantity per reel	Dimension P

Recommended Reflow Profile

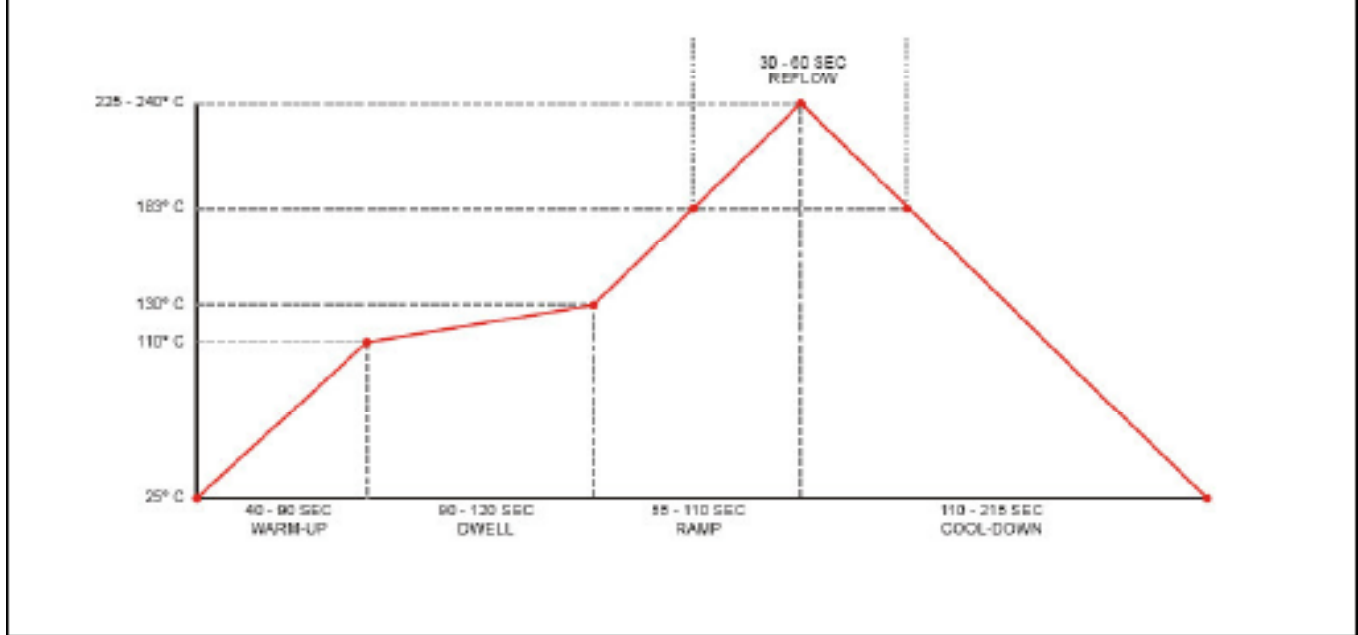

Outline Drawing / Enclosure

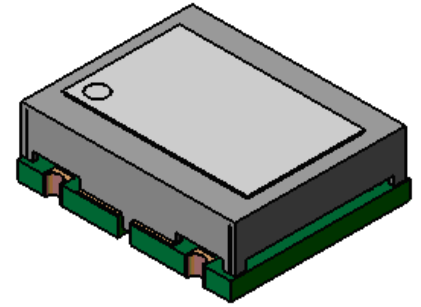
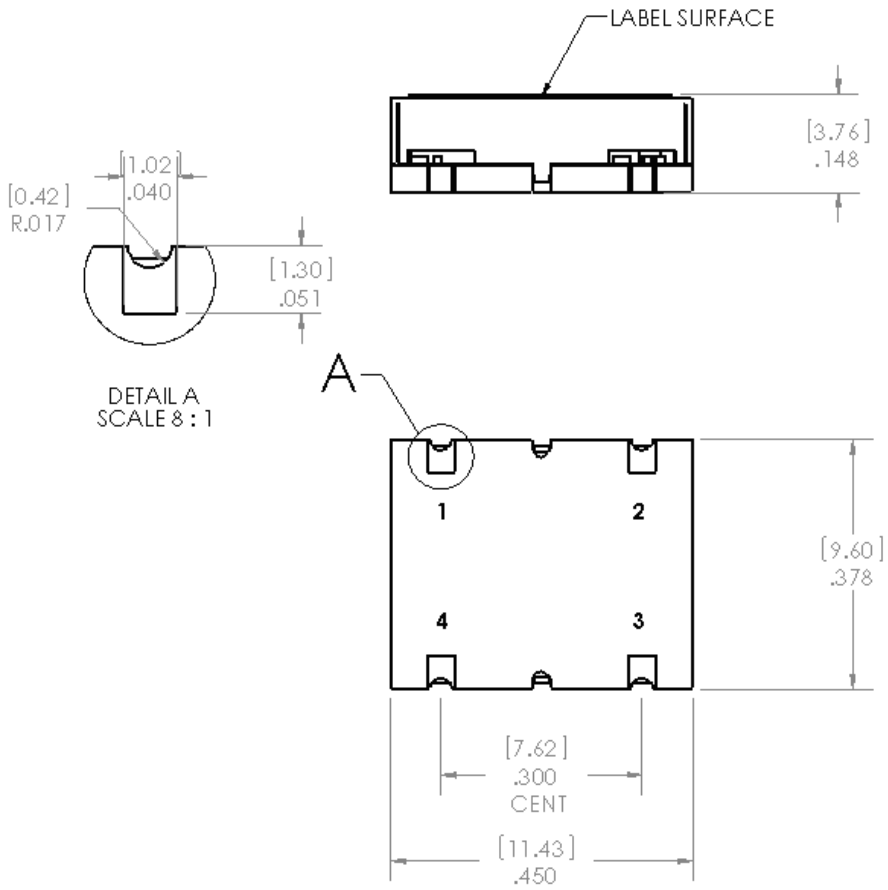

PIN NUMBERS SHOWN FOR REFERENCE ONLY

Dimensions in inches (mm)

TX-552 Pin Connections	
1	Electronic Frequency Control (EFC)
2	Ground
3	RF Output
4	Supply

Ordering Information

TX - 552 0 - D A E - 106 A - 10M0000000

Product Family
TX: TCXO

Package
9 x 11 mm

Height
0: 0.148"

Supply Voltage
D: 5 Vdc
E: 3.3 Vdc

RF Output Code
A: HCMOS
E: Sinewave $F \geq 30$ MHz
F: Clipped Sinewave $F \geq 30$ MHz

Frequency

Tuning Option
A: No Tuning
B: Electrical Tuning

Stability Code
206: ± 2.0 ppm
106: ± 1.0 ppm

Temperature Range
E: -40°C to $+85^{\circ}\text{C}$
F: -40°C to $+105^{\circ}\text{C}$

Available Frequencies (MHz) ⁶		
9.600	10.000	12.500
19.200	20.000	25.000
38.400	40.000	50.000
76.800	80.00	100.000

Notes:

- Contact factory for improved stabilities or additional product options. Not all options and codes are available at all frequencies.
- Unless other stated all values are valid after warm-up time and refer to typical conditions for supply voltage, frequency control voltage, load, temperature (25°C).
- Phase noise degrades with increasing output frequency.
- Subject to technical modification.
- Contact factory for availability.
- Frequencies not listed above may require NRE charges and additional lead times.

Contact Information

USA:

100 Watts Street
Mt Holly Springs, PA 17065
Tel: 1.717.486.3411
Fax: 1.717.486.5920

Europe:

Landstrasse
74924 Neckarbischofsheim
Germany
Tel: +49 (0) 7268.801.0
Fax: +49 (0) 7268.801.281



Information contained in this publication regarding device applications and the like is provided only for your convenience and may be superseded by updates. It is your responsibility to ensure that your application meets with your specifications. MICROCHIP MAKES NO REPRESENTATION OR WARRANTIES OF ANY KIND WHETHER EXPRESS OR IMPLIED, WRITTEN OR ORAL, STATUTORY OR OTHERWISE, RELATED TO THE INFORMATION INCLUDING, BUT NOT LIMITED TO ITS CONDITION, QUALITY, PERFORMANCE, MERCHANTABILITY OR FITNESS FOR PURPOSE. Microchip disclaims all liability arising from this information and its use. Use of Microchip devices in life support and/or safety applications is entirely at the buyer's risk, and the buyer agrees to defend, indemnify and hold harmless Microchip from any and all damages, claims, suits, or expenses resulting from such use. No licenses are conveyed, implicitly, or otherwise, under any Microchip intellectual property rights unless otherwise stated.

Trademarks

The Microchip and Vectron names and logos are registered trademarks of Microchip Technology Incorporated in the U.S.A. and other countries.