

---

---

## Temperature Compensated Crystal Oscillator

---

---

### Features

- Clipped Sine Wave or CMOS Output
- 10.000 MHz to 52.000 MHz Output
- $\pm 50$  ppb Temperature Stability
- Optional VCXO
- Fundamental Crystal Design
- Gold over Nickel Contact Pads
- Ceramic 5.0 mm x 3.2 mm SMD Package
- Product is Compliant to RoHS Directive and Fully Compatible with Lead-Free Assembly

### General Description

Microchip's VT-804B temperature compensated crystal oscillator (TCXO) is a quartz stabilized, clipped sine wave or CMOS output, 6th order analog temperature compensated oscillator that operates off a 2.5V to 3.3V supply in a 5.0 mm x 3.2 mm ceramic package.

### Applications

- Stratum 3
- SyncE
- 1588
- Femto Cells
- Base Stations
- IP Networking
- GPS
- Point-to-Point Radio
- Manpack Radio
- Test and Measurement

### Block Diagram

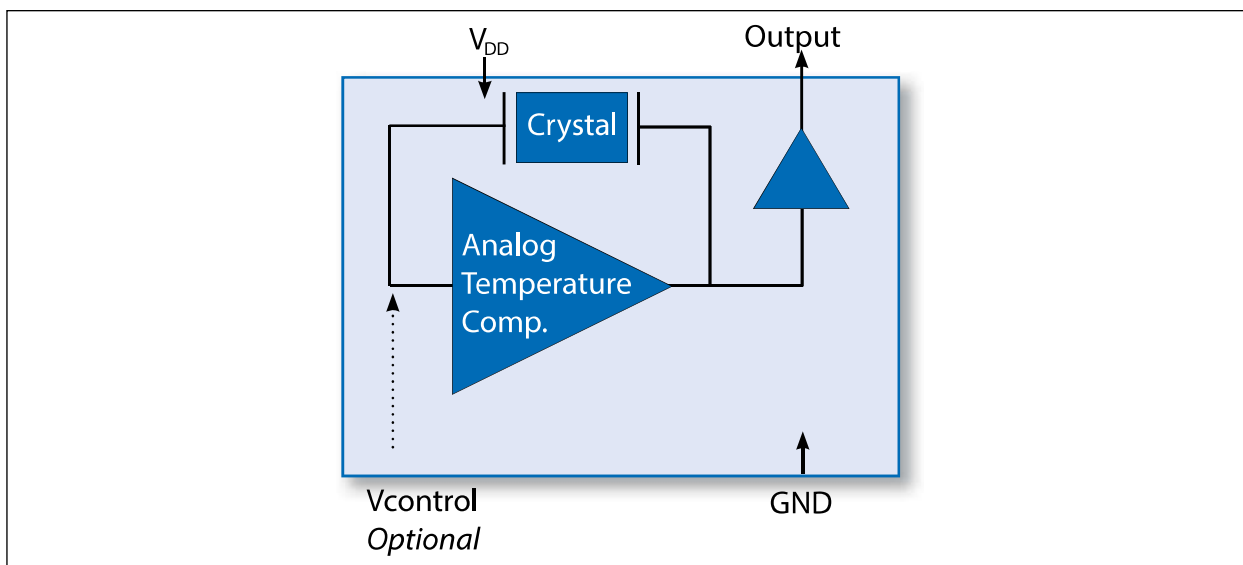

# VT-804B

## 1.0 ELECTRICAL CHARACTERISTICS

### Absolute Maximum Ratings †

Supply Voltage ( $V_{DD}$ )	–0.3V to +4.6V
Maximum Control Voltage ( $V_C$ )	–0.3V to $V_{DD} + 0.3V$
Enable/Disable Voltage	–0.3V to $V_{DD} + 0.3V$
ESD Rating, Human Body Model (Note 1)	2 kV
ESD Rating, Machine Model	200V
ESD Rating, Charged Device Model	750V
Storage Temperature ( $T_S$ )	–55°C to +125°C

† **Notice:** Stresses in excess of the Absolute Maximum Ratings can permanently damage the device. Functional operation is not implied at these or any other conditions in excess of conditions represented in the operational sections of this data sheet. Exposure to Absolute Maximum Ratings for extended periods may adversely affect device reliability.

**Note 1:** Although ESD protection circuitry has been designed into the VT-804B, proper precautions should be taken when handling and mounting. Microchip employs a Human Body Model (HBM) and a Charged Device Model (CDM) for ESD susceptibility testing and design evaluation. ESD thresholds are dependent on the circuit parameters used to define the model. Although no industry standard has been adopted for the CDM, a standard resistance of 1.5 k $\Omega$  and capacitance of 100 pF is widely used and therefore can be used for comparison purposes.

### ELECTRICAL CHARACTERISTICS, CLIPPED SINE WAVE OPTION

Parameter	Sym.	Min.	Typ.	Max.	Units	Conditions
Output Frequency, Note 1	$f_O$	10	—	52	MHz	Ordering Option
Supply Voltage, Note 2	$V_{DD}$	—	2.5	—	V	Ordering Option
		—	2.8	—		
		—	3.0	—		
		—	3.3	—		
Supply Current	$I_{DD}$	—	—	6.0	mA	$f_O \leq 40$ MHz
		—	—	8.0		$f_O > 40$ MHz
Operating Temperature	$T_{OP}$	–20	—	+70	°C	Ordering Option
		–40	—	+85		
		–40	—	+105		

**Note 1:** The output is DC-coupled.

- 2: The VT-804B power supply pin should be filtered using a bypass capacitor, such as 10  $\mu$ F, 0.1  $\mu$ F, and 0.01  $\mu$ F.
- 3: Not all stabilities are available over all temperature ranges. Measured at mid  $V_C$  for parts with frequency tuning.
- 4: After two IR reflows and 24 hours.
- 5:  $\pm 50$  ppb,  $\pm 100$  ppb,  $\pm 200$  ppb, and  $\pm 280$  ppb temperature stability parts, all inclusive with 10 years' aging.
- 6: Output is enabled if E/D is left open.
- 7: Measured at room ambient temperature using an Agilent E5052B Signal Source Analyzer or equivalent.

## ELECTRICAL CHARACTERISTICS, CLIPPED SINE WAVE OPTION (CONTINUED)

Parameter	Sym.	Min.	Typ.	Max.	Units	Conditions
<b>Frequency Stability</b>						
Stability over Operating Temperature, <a href="#">Note 3</a>	$f_{\text{STAB}}$	—	—	±50	ppb	Ordering Option
		—	—	±100		
		—	—	±200		
		—	—	±280		
		—	—	±500	ppm	
		—	—	±1.0		
		—	—	±2.0		
		—	—	±3.0		
		—	—	±4.0		
—	—	±5.0				
Initial Accuracy “No Adjust Option”	—	—	—	±1.5	ppm	<a href="#">Note 4</a>
Power Supply Stability, ±5% Change	—	—	—	±0.10	ppm	—
Load Stability, ±10% Change	—	—	—	±0.10	ppm	—
Aging	—	—	—	±0.5	ppm	First year
Stability, Temperature, and 24 Hours	—	—	—	±0.37	ppm	<a href="#">Note 5</a>
Total Stability, <a href="#">Note 5</a>	—	—	—	±4.6	ppm	—
Pull Range	PR	±5	—	—	ppm	Ordering Option
Control Voltage to Reach Pull Range	—	0.5	—	2.5	V	—
Control Voltage Impedance	—	100	—	—	kΩ	—
<b>RF Output</b>						
Output Level	$V_{\text{O\_PP}}$	0.8	—	—	V	—
Output Load	—	—	—	10K   10 pF	—	—
Duty Cycle	DC	45	—	55	%	—
Phase Noise, 10 Hz	$\emptyset_N$	—	-91	—	dBc/Hz	26.00 MHz, <a href="#">Note 7</a>
Phase Noise, 100 Hz		—	-110	—		
Phase Noise, 1 kHz		—	-136	—		
Phase Noise, 10 kHz		—	-150	—		
Phase Noise, 100 kHz		—	-158	—		
Start-Up Time	$t_{\text{SU}}$	—	—	10	ms	—

**Note 1:** The output is DC-coupled.

**2:** The VT-804B power supply pin should be filtered using a bypass capacitor, such as 10 μF, 0.1 μF, and 0.01 μF.

**3:** Not all stabilities are available over all temperature ranges. Measured at mid  $V_C$  for parts with frequency tuning.

**4:** After two IR reflows and 24 hours.

**5:** ±50 ppb, ±100 ppb, ±200 ppb, and ±280 ppb temperature stability parts, all inclusive with 10 years' aging.

**6:** Output is enabled if E/D is left open.

**7:** Measured at room ambient temperature using an Agilent E5052B Signal Source Analyzer or equivalent.

# VT-804B

## ELECTRICAL CHARACTERISTICS, CMOS OPTION

Parameter	Sym.	Min.	Typ.	Max.	Units	Conditions
Output Frequency, <a href="#">Note 1</a>	$f_O$	10	—	52	MHz	Ordering Option
Supply Voltage, <a href="#">Note 2</a>	$V_{DD}$	—	2.5	—	V	Ordering Option
		—	2.8	—		
		—	3.0	—		
		—	3.3	—		
Supply Current	$I_{DD}$	—	—	6.0	mA	$f_O \leq 40$ MHz
		—	—	8.0		$f_O > 40$ MHz
Operating Temperature	$T_{OP}$	−20	—	+70	°C	Ordering Option
		−40	—	+85		
		−40	—	+105		
<b>Frequency Stability</b>						
Stability over Operating Temperature, <a href="#">Note 3</a>	$f_{STAB}$	—	—	±50	ppb	Ordering Option
		—	—	±100		
		—	—	±200		
		—	—	±280		
		—	—	±500	ppm	
		—	—	±1.0		
		—	—	±2.0		
		—	—	±3.0		
		—	—	±4.0		
		—	—	±5.0		
Initial Accuracy “No Adjust Option”	—	—	—	±1.5	ppm	<a href="#">Note 4</a>
Power Supply Stability, ±5% Change	—	—	—	±0.10	ppm	—
Load Stability, ±10% Change	—	—	—	±0.10	ppm	—
Aging	—	—	—	±0.5	ppm	First year
Stability, Temperature, and 24 Hours	—	—	—	±0.37	ppm	<a href="#">Note 5</a>
Total Stability, <a href="#">Note 5</a>	—	—	—	±4.6	ppm	—
Pull Range	PR	±5	—	—	ppm	Ordering Option
Control Voltage to Reach Pull Range	—	0.5	—	2.5	V	—

**Note 1:** The output is DC-coupled.

**2:** The VT-804B power supply pin should be filtered using a bypass capacitor, such as 10  $\mu$ F, 0.1  $\mu$ F, and 0.01  $\mu$ F.

**3:** Not all stabilities are available over all temperature ranges. Measured at mid  $V_C$  for parts with frequency tuning.

**4:** After two IR reflows and 24 hours.

**5:** ±50 ppb, ±100 ppb, ±200 ppb, and ±280 ppb temperature stability parts, all inclusive with 10 years' aging.

**6:** Measured at room ambient temperature using an Agilent E5052B Signal Source Analyzer or equivalent.

## ELECTRICAL CHARACTERISTICS, CMOS OPTION (CONTINUED)

Parameter	Sym.	Min.	Typ.	Max.	Units	Conditions
Control Voltage Impedance	—	100	—	—	k $\Omega$	—
<b>RF Output</b>						
Output Logic Level High	V <sub>OH</sub>	0.9 * V <sub>DD</sub>	—	—	V	—
Output Logic Level Low	V <sub>OL</sub>	—	—	0.1 * V <sub>DD</sub>	V	—
Output Logic Level High Drive	—	—	—	-4	mA	—
Output Logic Level Low Drive	—	4	—	—	mA	—
Rise/Fall Time	t <sub>r</sub> /t <sub>f</sub>	—	—	7	ns	—
Output Load	—	—	—	15	pF	—
Duty Cycle	DC	45	—	55	%	—
Phase Noise, 10 Hz	$\emptyset_N$	—	-91	—	dBc/Hz	26.00 MHz, <a href="#">Note 6</a>
Phase Noise, 100 Hz		—	-110	—		
Phase Noise, 1 kHz		—	-136	—		
Phase Noise, 10 kHz		—	-150	—		
Phase Noise, 100 kHz		—	-158	—		
Start-Up Time	t <sub>SU</sub>	—	—	10	ms	—

- Note 1:** The output is DC-coupled.
- 2:** The VT-804B power supply pin should be filtered using a bypass capacitor, such as 10  $\mu$ F, 0.1  $\mu$ F, and 0.01  $\mu$ F.
- 3:** Not all stabilities are available over all temperature ranges. Measured at mid V<sub>C</sub> for parts with frequency tuning.
- 4:** After two IR reflows and 24 hours.
- 5:**  $\pm$ 50 ppb,  $\pm$ 100 ppb,  $\pm$ 200 ppb, and  $\pm$ 280 ppb temperature stability parts, all inclusive with 10 years' aging.
- 6:** Measured at room ambient temperature using an Agilent E5052B Signal Source Analyzer or equivalent.

## 2.0 VCXO FUNCTION

The VT-804B is supplied with a VCXO function for applications where it will be used in a PLL or where the output frequency needs fine tuning or calibration adjustments. This is a high-impedance input, 100 k $\Omega$ , and can be driven with an op-amp or terminated with adjustable resistors. Pin 1 should not be left floating on the VCXO-optional device.

# VT-804B

## 3.0 PIN DESCRIPTIONS

The descriptions of the pins are listed in [Table 3-1](#).

**TABLE 3-1: PIN FUNCTION TABLE**

Pin Number	Pin Name	Description
1	V <sub>C</sub> or NC	TCXO Control Voltage or No connection.
2	GND	Ground.
3	OUT	Frequency output.
4	V <sub>DD</sub>	Supply voltage.

## 4.0 RELIABILITY

Microchip qualification will include aging at various extreme temperatures, shock and vibration, temperature cycling, and IR reflow simulation. The VT-804B is capable of meeting the following qualification tests.

**TABLE 4-1: ENVIRONMENTAL COMPLIANCE**

Parameter	Conditions
Mechanical Shock	IEC 60068-2-6
Mechanical Vibration	IEC 60068-2-27
Drop Test	EUAJ-ED-4702C, Method 5
Thermal Shock	IEC 60068-2-14
Solderability	IEC 60068-2-58
High Temperature Storage	IEC 60068-2-2 Bb
Low Temperature Storage	IEC 60068-2-1 Ab
Humidity	IEC 60068-2-78
Moisture Sensitivity Level	MSL 1
Contact Pads	Gold over Nickel
Weight	80 mg

## 5.0 IR REFLOW

Devices are built using lead-free epoxy and can be subjected to standard lead-free IR reflow conditions shown in Table 5-1. Contact pads are gold over nickel and lower maximum temperatures can also be used, such as 220°C.

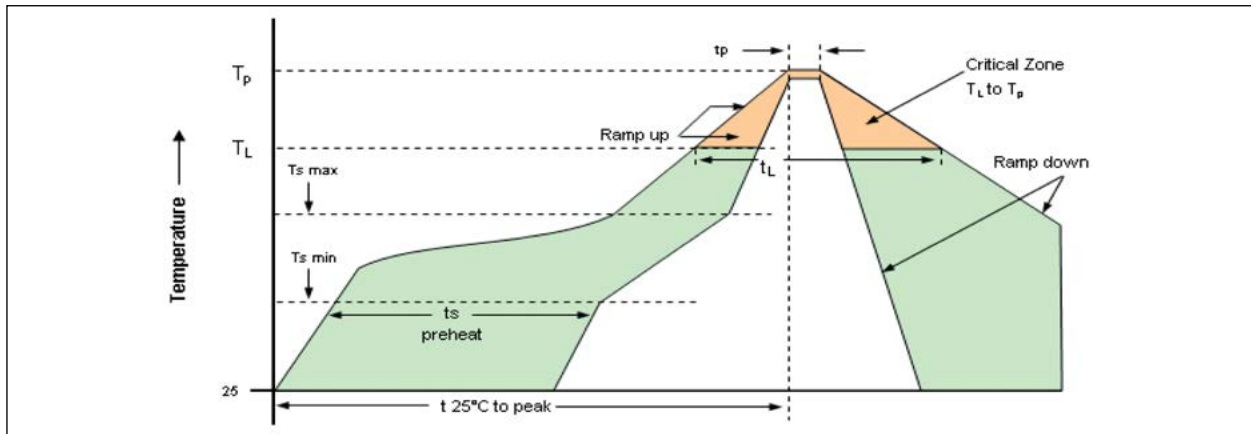

FIGURE 5-1: Solder Profile.

TABLE 5-1: REFLOW PROFILE

Parameter	Symbol	Value
Pre-Heat Time	$t_s$	200 seconds maximum
	$t_{s(MIN)}$	150°C
	$t_{s(MAX)}$	200°C
Ramp Up	$R_{UP}$	3°C/sec. maximum
Time above 217°C	$t_L$	150 seconds maximum
Time to Peak Temperature	$T_{AMB-P}$	480 seconds maximum
Time at 260°C	$t_p$	30 seconds maximum
Time at 240°C	$t_{p2}$	60 seconds maximum
Ramp Down	$R_{DN}$	6°C/sec. maximum

## 6.0 TAPE AND REEL

TABLE 6-1: TAPE AND REEL DIMENSIONS

Tape Dimensions (mm)						Reel Dimensions (mm)							
Dimension	W	F	Do	Po	P1	A	B	C	D	N	W1	W2	# per Reel
Tolerance	Typ	Typ	Typ	Typ	Typ	Typ	Typ	Typ	Typ	Typ	Typ	Max	
VT-804B	12	5.5	1.5	4	8	254	2.5	13	21	100	13.5	17.5	1000

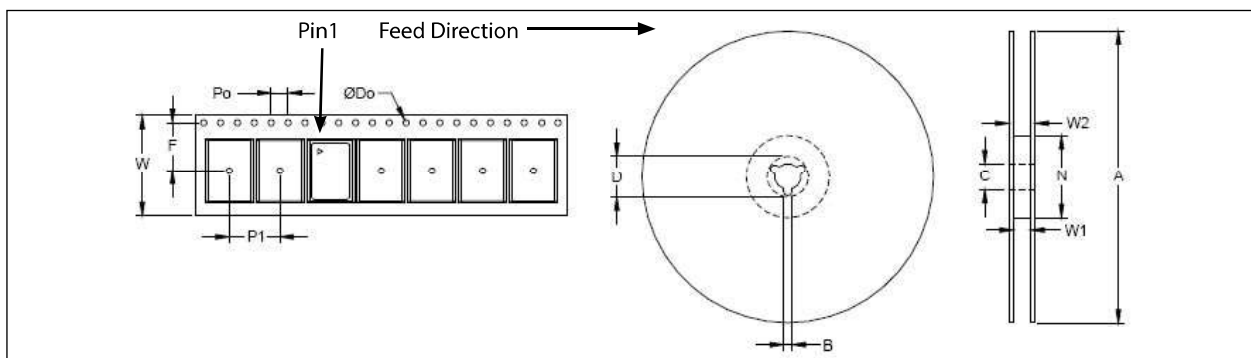

# VT-804B

## 7.0 PACKAGING INFORMATION

### 4-Lead 3.2 mm x 2.5 mm Ceramic Leadless Chip Carrier Package Outline (4TW) and Recommended Land Pattern

**Note:** For the most current package drawings, please see the Microchip Packaging Specification located at <http://www.microchip.com/packaging>

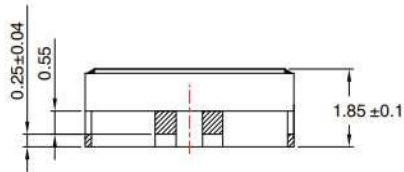
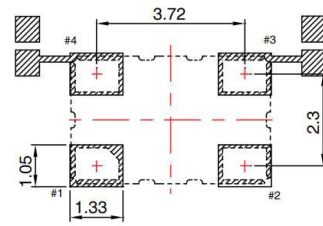
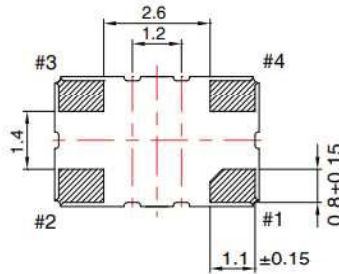
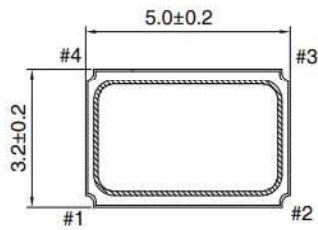

#### Marking

VXXMXX

.YYWWT

XXMXX = Frequency eg 25M00 = 25.000MHz

YY=Year

WW=Week

T=Manufacturing Location

## APPENDIX A: REVISION HISTORY

### Revision A (January 2025)

- Converted Vectron document VT-804B to Microchip data sheet template DS20006963A.
- Minor grammatical text changes throughout.

# VT-804B

---

NOTES:

## PRODUCT IDENTIFICATION SYSTEM

To order or obtain information, e.g., on pricing or delivery, contact your local Microchip representative or sales office.

<u>Device</u>	<u>-X</u>	<u>X</u>	<u>X</u>	<u>-XXX</u>	<u>X</u>	<u>-XXXXXXXXXX</u>	<u>XX</u>
Part No.	Power Supply	Output	Temp. Range	Stability	Tuning	Frequency	Packaging
<b>Device:</b>	VT-804B: Temperature Compensated Crystal Oscillator in a 5.0 mm x 3.2 mm CLCC						
<b>Power Supply:</b>	E = 3.3VDC ±10%						
	F = 3.0VDC ±10%						
	G = 2.8VDC ±10%						
	H = 2.5VDC ±10%						
<b>Output:</b>	A = CMOS						
	F = Clipped Sine Wave						
<b>Temperature Range:</b>	J = -20°C to +70°C						
	E = -40°C to +85°C						
	F = -40°C to +105°C						
	508 = ±50 ppb						
	107 = ±100 ppb						
	207 = ±200 ppb						
	287 = ±280 ppb						
<b>Stability:</b>	507 = ±500 ppb						
	106 = ±1.0 ppm						
	206 = ±2.0 ppm						
	306 = ±3.0 ppm						
	406 = ±4.0 ppm						
	506 = ±5.0 ppm						
<b>Tuning:</b>	0 = Fixed, No Tuning						
	A = ±5 ppm						
<b>Frequency:</b>	xxMxxxxxx=Frequency in MHz						
<b>Packaging:</b>	TR = 1,000/Reel						
	<blank>= Cut Tape/ non-TR quantities						
<b>Examples:</b>							
a) VT-804B-HAF-287A-50M000000TR VT-804B, 2.5V, CMOS Output, -40°C to +105°C Temp. Range, ±280 ppb Stability, ±5 ppm Tuning, 50 MHz Frequency, 1000/Reel							
b) VT-804B-EFE-5060-12M8000000 VT-804B, 3.3V, Clipped Sine Wave Output, -40°C to +85°C Temp. Range, ±5.0 ppm Stability, No Tuning, 12.800 MHz Frequency, Cut Tape							
c) VT-804B-FAJ-106A-20M000000TR VT-804B, 3.0V, CMOS Output, -20°C to +70°C Temp. Range, ±1.0 ppm Stability, ±5 ppm Tuning, 20 MHz Frequency, 1000/Reel							
d) VT-804B-HFJ-5080-30M7200000 VT-804B, 2.5V, Clipped Sine Wave Output, -20°C to +70°C Temp. Range, ±50 ppb Stability, No Tuning, 30.720 MHz Frequency, Cut Tape							
<b>Note 1:</b> Tape and Reel identifier only appears in the catalog part number description. This identifier is used for ordering purposes and is not printed on the device package. Check with your Microchip Sales Office for package availability with the Tape and Reel option.							

**TABLE 1: STANDARD FREQUENCIES**

10.000 MHz	12.800 MHz	13.000 MHz	19.200 MHz	20.000 MHz	25.000 MHz
26.000 MHz	30.720 MHz	—	—	—	—

# VT-804B

---

NOTES:

---

---

## Microchip Information

### Trademarks

The “Microchip” name and logo, the “M” logo, and other names, logos, and brands are registered and unregistered trademarks of Microchip Technology Incorporated or its affiliates and/or subsidiaries in the United States and/or other countries (“Microchip Trademarks”). Information regarding Microchip Trademarks can be found at <https://www.microchip.com/en-us/about/legalinformation/microchip-trademarks>.

ISBN: 979-8-3371-0422-5

### Legal Notice

This publication and the information herein may be used only with Microchip products, including to design, test, and integrate Microchip products with your application. Use of this information in any other manner violates these terms. Information regarding device applications is provided only for your convenience and may be superseded by updates. It is your responsibility to ensure that your application meets with your specifications. Contact your local Microchip sales office for additional support or, obtain additional support at [www.microchip.com/en-us/support/design-help/client-support-services](http://www.microchip.com/en-us/support/design-help/client-support-services).

THIS INFORMATION IS PROVIDED BY MICROCHIP "AS IS". MICROCHIP MAKES NO REPRESENTATIONS OR WARRANTIES OF ANY KIND WHETHER EXPRESS OR IMPLIED, WRITTEN OR ORAL, STATUTORY OR OTHERWISE, RELATED TO THE INFORMATION INCLUDING BUT NOT LIMITED TO ANY IMPLIED WARRANTIES OF NON-INFRINGEMENT, MERCHANTABILITY, AND FITNESS FOR A PARTICULAR PURPOSE, OR WARRANTIES RELATED TO ITS CONDITION, QUALITY, OR PERFORMANCE.

IN NO EVENT WILL MICROCHIP BE LIABLE FOR ANY INDIRECT, SPECIAL, PUNITIVE, INCIDENTAL, OR CONSEQUENTIAL LOSS, DAMAGE, COST, OR EXPENSE OF ANY KIND WHATSOEVER RELATED TO THE INFORMATION OR ITS USE, HOWEVER CAUSED, EVEN IF MICROCHIP HAS BEEN ADVISED OF THE POSSIBILITY OR THE DAMAGES ARE FORESEEABLE. TO THE FULLEST EXTENT ALLOWED BY LAW, MICROCHIP'S TOTAL LIABILITY ON ALL CLAIMS IN ANY WAY RELATED TO THE INFORMATION OR ITS USE WILL NOT EXCEED THE AMOUNT OF FEES, IF ANY, THAT YOU HAVE PAID DIRECTLY TO MICROCHIP FOR THE INFORMATION.

Use of Microchip devices in life support and/or safety applications is entirely at the buyer's risk, and the buyer agrees to defend, indemnify and hold harmless Microchip from any and all damages, claims, suits, or expenses resulting from such use. No licenses are conveyed, implicitly or otherwise, under any Microchip intellectual property rights unless otherwise stated.

### Microchip Devices Code Protection Feature

Note the following details of the code protection feature on Microchip products:

- Microchip products meet the specifications contained in their particular Microchip Data Sheet.
- Microchip believes that its family of products is secure when used in the intended manner, within operating specifications, and under normal conditions.
- Microchip values and aggressively protects its intellectual property rights. Attempts to breach the code protection features of Microchip product is strictly prohibited and may violate the Digital Millennium Copyright Act.
- Neither Microchip nor any other semiconductor manufacturer can guarantee the security of its code. Code protection does not mean that we are guaranteeing the product is “unbreakable”. Code protection is constantly evolving. Microchip is committed to continuously improving the code protection features of our products.