

12.7-16GHz MMIC POWER AMPLIFIER

FEATURES:

- Balanced Topology
- 37dBm OIP3
- 30dB Gain
- Input Return Loss <-15dB
- Output Return Loss <-15dB

GENERAL DESCRIPTION:

The FMA3011 is a high performance 12.7-16GHz Gallium Arsenide monolithic power amplifier with sufficiently high gain to ensure that IMD products from preceding stages can be kept to an absolute minimum. Coupled with the low IMD of this device, highly linear system performance can be achieved, while preserving the overall system gain requirements. It is suitable for use in digital microwave radios and electronic warfare applications. Balanced configuration using Lange couplers ensures excellent return losses and tolerance to external loads. The input stage is self-biased.

FUNCTIONAL SCHEMATIC:

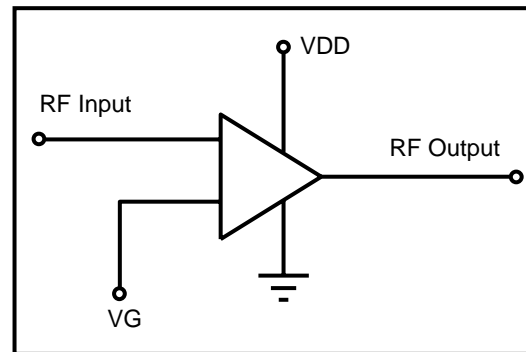

TYPICAL APPLICATIONS:

- Electronic Warfare
- Broadband Communication Infrastructure
- Cellular Backhaul
- Point-to-Point Radio

ELECTRICAL SPECIFICATIONS (ON-WAFER):

PARAMETER	CONDITIONS (VDD=6.8V, ID=450mA)	MIN	TYP	MAX	UNITS
Small Signal Gain	13 GHz, pulsed	27.7	30.5	32.3	dB
	15 GHz, pulsed	25.2	28.5	31.7	dB
Input Return Loss	12.5 – 15.5 GHz, Vdd=5V, Vg=-0.5V		-13	-10.7	dB
Output Return Loss	12.5 – 15.5 GHz, Vdd=5V, Vg=-0.5V		-14	-13.7	dB
P _{1dB}	13 – 15 GHz, pulsed	26	29.2	32	dBm
3rd Order Output Intercept Point (OIP3) (jig measurement)	13GHz (measured at 22dBm total output power)	35.5	37		dBm
	15GHz (measured at 22dBm total output power)	35.5	37		dBm
Noise Figure (jig measurement)	13 GHz		4.1	4.5	dB
	15 GHz		4.7	5.3	dB
Self-bias Current	Total for both input stages	40	60	100	mA

Note: T_{AMBIENT} = +25°C, Z₀ = 50

ABSOLUTE MAXIMUM RATINGS:

PARAMETER	SYMBOL	ABSOLUTE MAXIMUM
Max Input Power	Pin	+25dBm
Gate Voltage	VG1	-2V
Drain Voltage	VDD	+10V
Power Dissipation	Pdiss	3.5W
Operating Temp	Toper	-40°C to +85°C
Storage Temp	Tstor	-55°C to +150°C

Note: Exceeding any one of these absolute maximum ratings may cause permanent damage to the device.

PAD LAYOUT:

PAD REF	PAD NAME	DESCRIPTION	PIN COORDINATES (µm)
A	I	RF in	(96,503)
B	D1A	1st Stage Drain	(671,2068)
C	G23A	2nd and 3rd Gate	(1721, 2068)
D	D2AA	2nd Drain Direct	(2171,2068)
E	D2AB	2nd Drain With Resistor	(2321,2068)
F	D3AB	3rd Drain With Resistor	(2471,2068)
G	D3AC	Alt 3rd Drain Direct	(3198,2040)
H	D3AA	3rd Stage Drain Direct	(3560,2068)
I	O	RF Output	(3604,1698)
J	D3BA	3rd Stage Drain Direct	(3560,132)
K	D3BC	Alt 3rd Drain Direct	(3198,160)
L	D3BB	3rd Drain With Resistor	(2471,132)
M	D2BB	2nd Drain With Resistor	(2321,132)
N	D2BA	2nd Drain Direct	(2171,132)
O	G23B	2nd and 3rd Gate	(1721,132)
P	D1B	1st Stage Drain	(671,132)

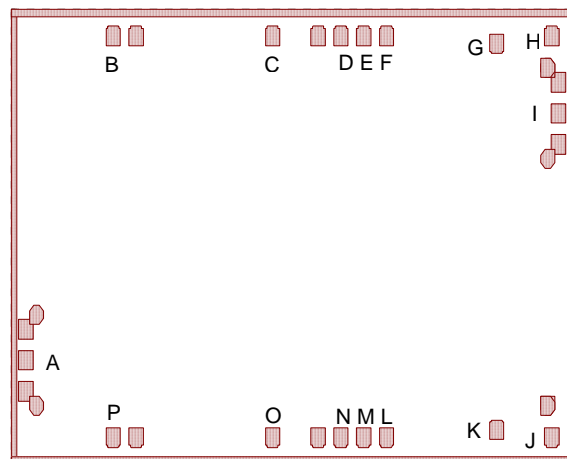

Note: Co-ordinates are referenced from the bottom left hand corner of the die to the centre of bond pad opening. Pads without identifiers are ground connections used in wafer testing.

DIE SIZE (µm)	DIE THICKNESS (µm)	MIN. BOND PAD PITCH (µm)	MIN. BOND PAD OPENING (µm x µm)
3700 x 2200	100	150um	100 x 100

TYPICAL PERFORMANCE FOR ON WAFER MEASUREMENTS:

Note: RF on wafer measurements conducted at a lower bias point. Gain increases to the typical value at full bias.

Measurement Conditions: $V_{G1} = -0.5V$, $I_D = 180mA$, $V_{DD} = 5V$, $T_{AMBIENT} = 25^\circ C$

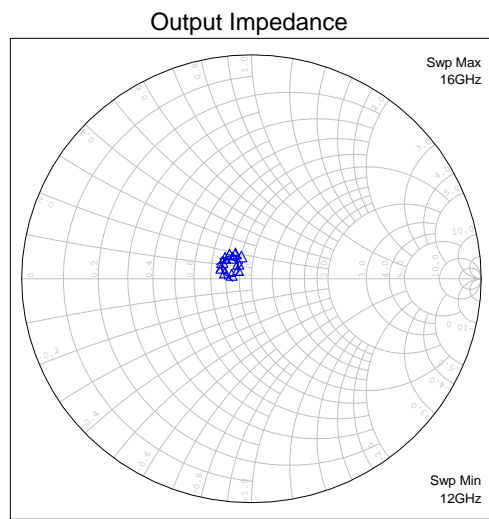
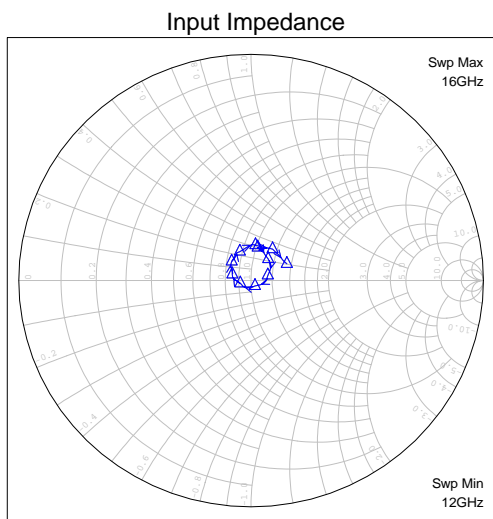
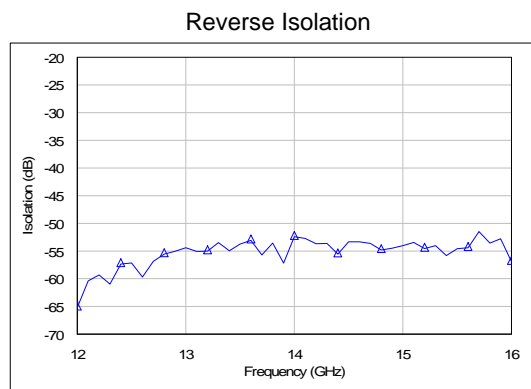
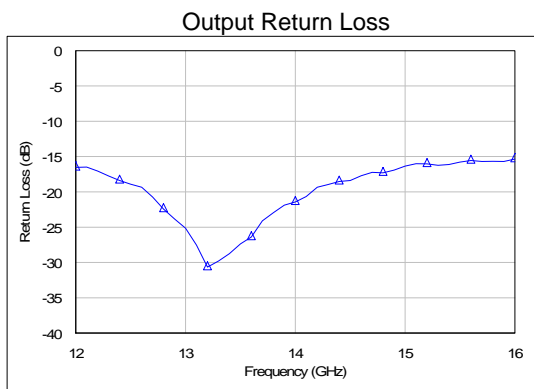
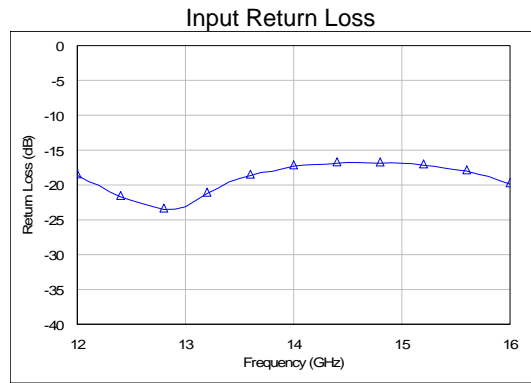
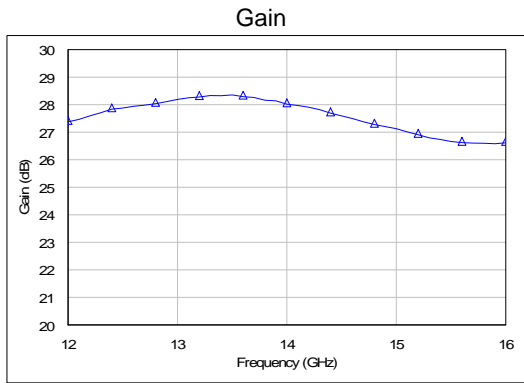

TYPICAL PERFORMANCE FOR ON WAFER MEASUREMENTS:

Note: RF on wafer measurements conducted at a lower bias point. Gain increases to the typical value at full bias.

Measurement Conditions: $V_{G1} = -0.5V$, $I_D = 180mA$, $V_{DD} = 5V$, $T_{AMBIENT} = 25^{\circ}C$

Frequency	ReS11	ImS11	ReS21	ImS21	ReS12	ImS12	ReS22	ImS22
12.000000	0.02862	0.14634	-6.67930	22.40440	-0.00002	-0.00055	-0.08042	0.08541
12.100000	0.04739	0.14199	-3.50866	23.34877	0.00065	-0.00070	-0.06926	0.08047
12.200000	0.05071	0.13091	-0.24776	23.97320	0.00030	-0.00104	-0.06486	0.07525
12.300000	0.05901	0.11523	3.18014	24.08470	0.00038	-0.00081	-0.05980	0.06616
12.400000	0.07374	0.09515	6.72798	23.70643	0.00028	-0.00133	-0.05717	0.05895
12.500000	0.08162	0.07863	10.21719	22.56068	0.00054	-0.00128	-0.05739	0.05220
12.600000	0.08652	0.06465	13.39561	21.06022	0.00018	-0.00102	-0.05660	0.04683
12.700000	0.08131	0.04328	16.42668	18.92982	0.00102	-0.00101	-0.05818	0.03881
12.800000	0.07224	0.02250	19.08678	16.47102	0.00107	-0.00128	-0.05909	0.03077
12.900000	0.06434	-0.00163	21.43423	13.71294	0.00135	-0.00114	-0.06285	0.02316
13.000000	0.05353	-0.01339	23.36681	10.66305	0.00138	-0.00131	-0.06789	0.01570
13.100000	0.03684	-0.02027	24.87215	7.07652	0.00152	-0.00090	-0.07716	0.01088
13.200000	0.01690	-0.02392	25.72424	3.35031	0.00157	-0.00083	-0.08625	0.00932
13.300000	-0.00248	-0.03228	26.09245	-0.53323	0.00209	-0.00036	-0.09435	0.00948
13.400000	-0.01801	-0.03173	25.70407	-4.42088	0.00170	-0.00056	-0.10434	0.01258
13.500000	-0.03347	-0.02676	24.80453	-8.34490	0.00205	-0.00013	-0.11028	0.01474
13.600000	-0.04619	-0.01233	23.09648	-11.90000	0.00219	-0.00038	-0.11522	0.01902
13.700000	-0.06234	-0.00087	21.00504	-15.11085	0.00164	0.00006	-0.12067	0.02500
13.800000	-0.07110	0.00140	18.32389	-17.87180	0.00200	0.00062	-0.12163	0.02956
13.900000	-0.07895	0.01599	15.46391	-20.31469	0.00136	0.00027	-0.12588	0.03534
14.000000	-0.08032	0.02743	12.11258	-22.07279	0.00233	0.00054	-0.13015	0.04070
14.100000	-0.08049	0.04620	8.78339	-23.44850	0.00222	0.00064	-0.13013	0.04824
14.200000	-0.08831	0.06197	5.16222	-24.30297	0.00178	0.00106	-0.12897	0.05541
14.300000	-0.08713	0.07151	1.55327	-24.54886	0.00197	0.00069	-0.12704	0.06067
14.400000	-0.08305	0.08453	-2.05811	-24.14934	0.00129	0.00105	-0.12680	0.06672
14.500000	-0.07201	0.09639	-5.39476	-23.34800	0.00180	0.00118	-0.12620	0.07174
14.600000	-0.06335	0.11361	-8.61700	-22.07628	0.00192	0.00099	-0.12231	0.07730
14.700000	-0.06197	0.12273	-11.48291	-20.37179	0.00166	0.00126	-0.11860	0.08131
14.800000	-0.04812	0.12781	-14.12595	-18.29621	0.00163	0.00080	-0.11485	0.08523
14.900000	-0.03018	0.13962	-16.44033	-15.96085	0.00146	0.00120	-0.11173	0.09098
15.000000	-0.00996	0.15195	-18.40505	-13.31864	0.00124	0.00156	-0.10638	0.09579
15.100000	0.00530	0.15823	-19.86278	-10.37735	0.00121	0.00175	-0.10103	0.09968
15.200000	0.01873	0.15667	-20.88333	-7.40515	0.00121	0.00143	-0.09553	0.10018
15.300000	0.03561	0.15014	-21.43556	-4.37013	0.00093	0.00176	-0.08894	0.10282
15.400000	0.05833	0.14512	-21.67941	-1.27367	0.00029	0.00159	-0.08270	0.10265
15.500000	0.07723	0.14294	-21.46588	1.79864	0.00053	0.00179	-0.07516	0.10419
15.600000	0.09221	0.13881	-20.88945	4.79123	0.00064	0.00179	-0.06926	0.10464
15.700000	0.10365	0.12732	-19.93439	7.75941	0.00080	0.00255	-0.06143	0.10268
15.800000	0.12069	0.11209	-18.55769	10.59434	-0.00001	0.00210	-0.05579	0.10057
15.900000	0.13756	0.08919	-16.75654	13.19331	0.00010	0.00229	-0.04917	0.09557
16.000000	0.15418	0.07345	-14.71157	15.56911	-0.00011	0.00142	-0.04345	0.09163

TYPICAL PERFORMANCE FOR FULL BIAS JIG BASED MEASUREMENTS:

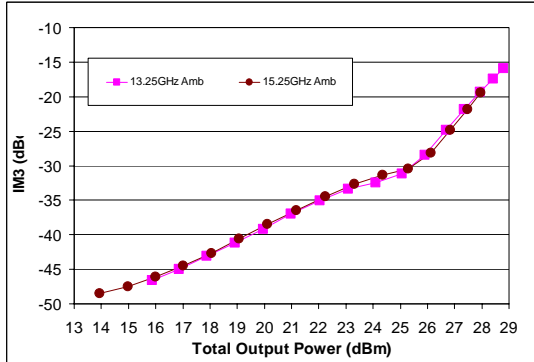
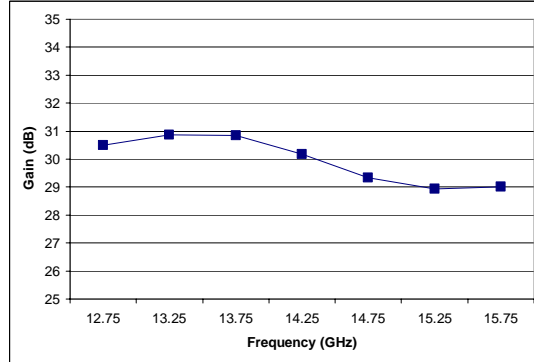
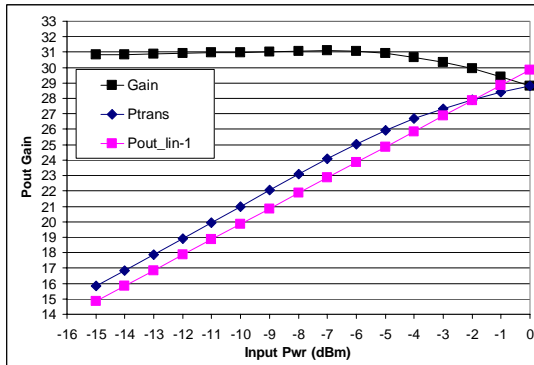
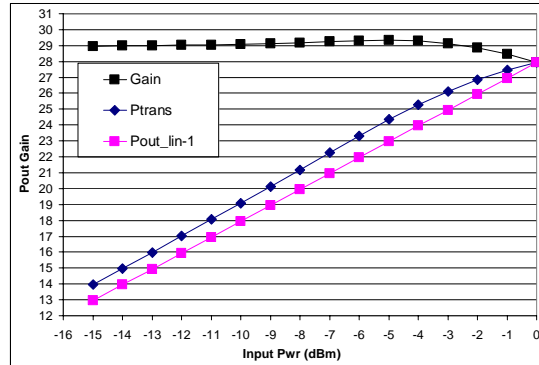
 Note: Measurement Conditions: $V_G = -0.35V$, $V_{DD} = 7V$, $I_d = 450mA$
IM3 Level (dBc) vs Total Output Power (dBm)

Gain

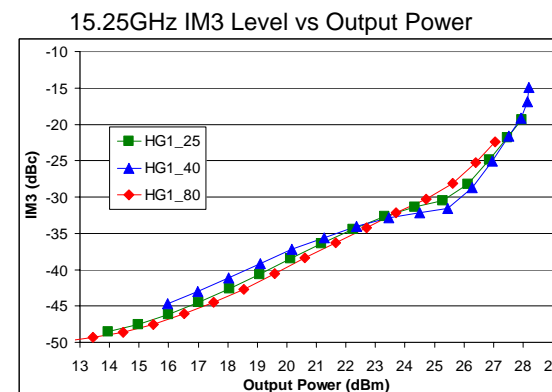
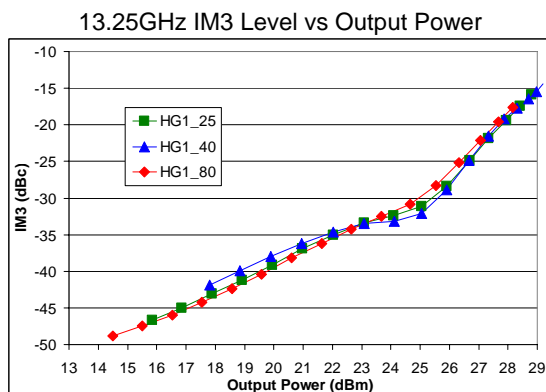
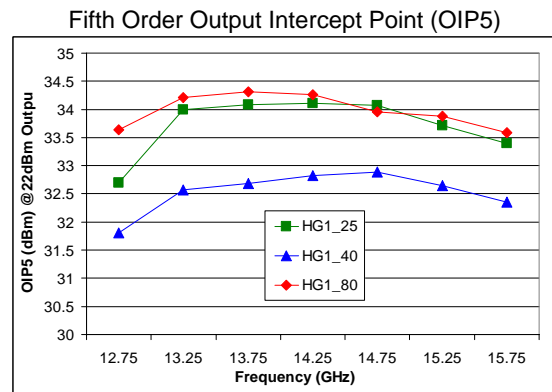
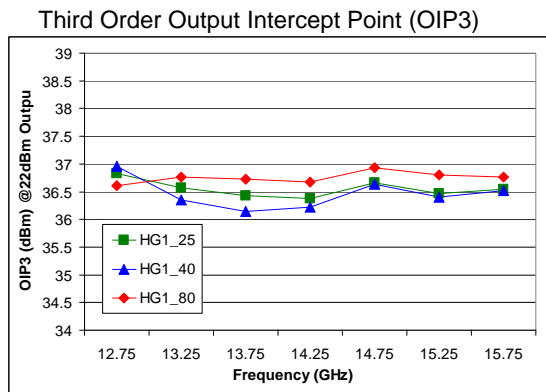
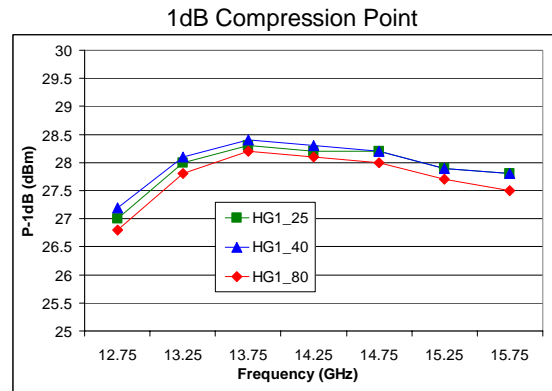
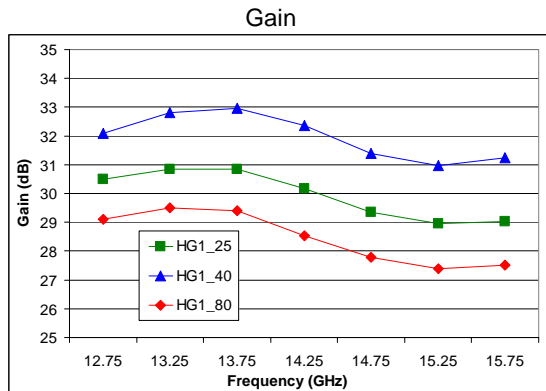
Power Transfer Characteristic 13GHz P-1dB

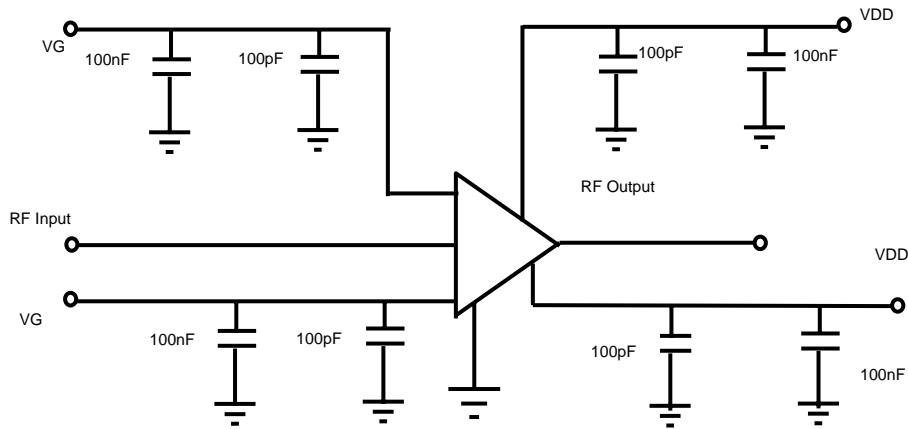
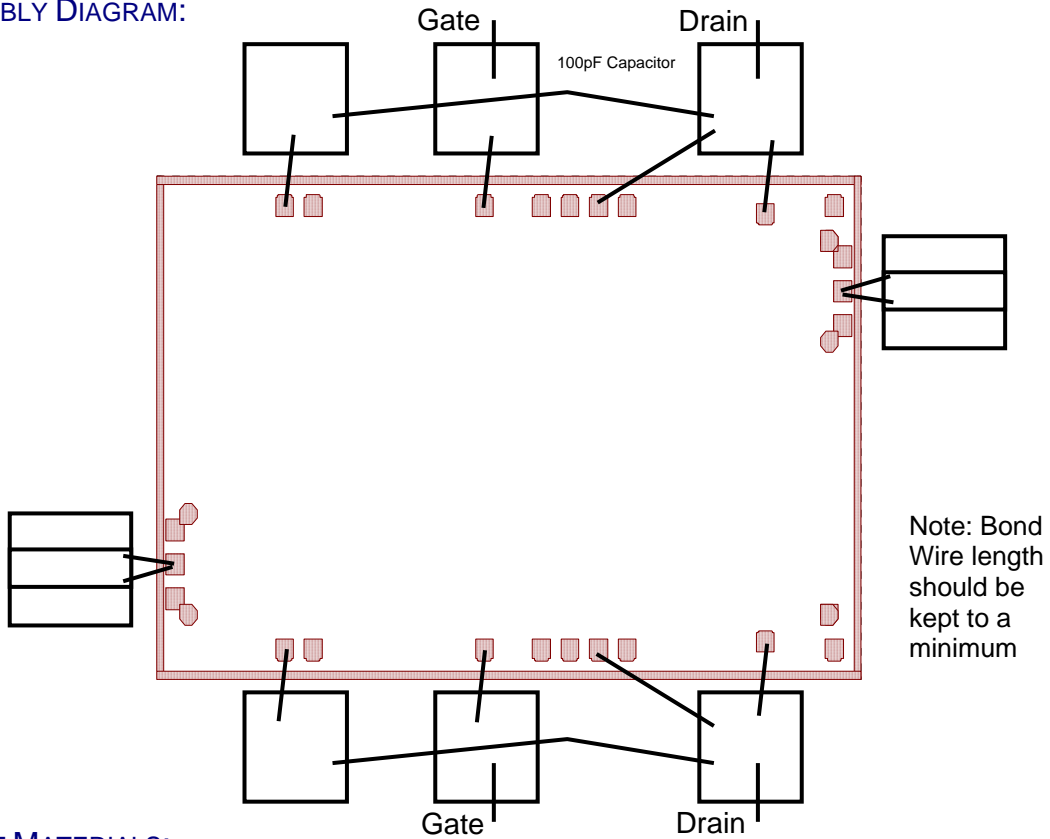
Power Transfer Characteristic 15GHz P-1dB

TYPICAL PERFORMANCE FOR FULL BIAS JIG BASED TEMPERATURE MEASUREMENTS:

 Note: Measurement Conditions: $V_G = -0.35V$, $V_{DD} = 7V$, $I_d = 450mA$ $T_{AMBIENT} = -40^{\circ}C$, $+25^{\circ}C$ and $+80^{\circ}C$

BIASING CIRCUIT SCHEMATIC:

ASSEMBLY DIAGRAM:

BILL OF MATERIALS:

LABEL	COMPONENT
Board	All RF tracks should be 50Ω characteristic material
C1	Capacitor, 100pF, chip capacitor
C2	Capacitor, 100nF, 0402

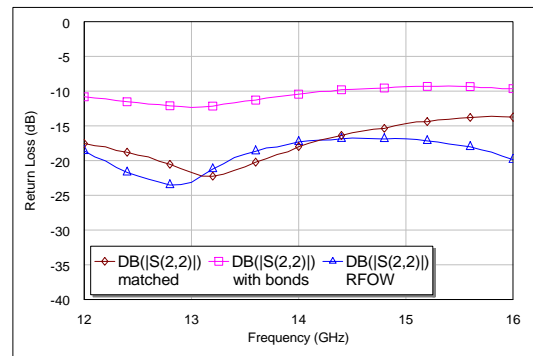
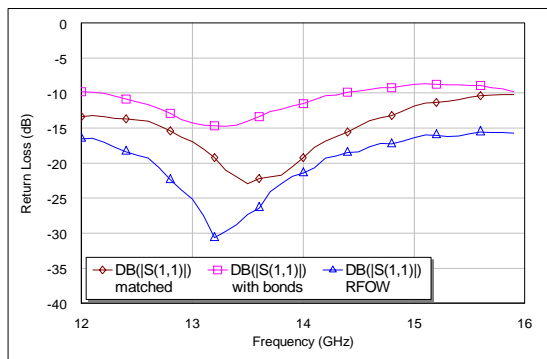
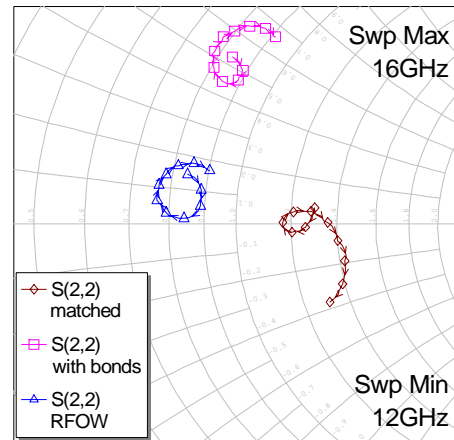
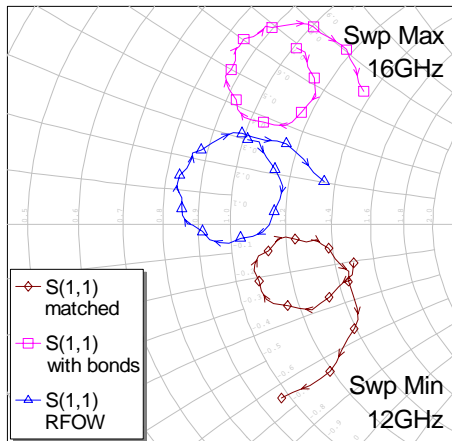
EFFECT OF BONDWIRES AND BOND COMPENSATION:

A pair of bondwires in the 'V' formation shown in the figure above, should if kept reasonably short, yield a combined inter-connect inductance of below 0.25nH. The FMA3011 has excellent return losses (blue triangles) and these are modified by the addition of a 0.25nH bondwire inductance (pink squares) as shown in the figures below.



Dimensions in mm. Material is 10 thou 4350
Er=3.38

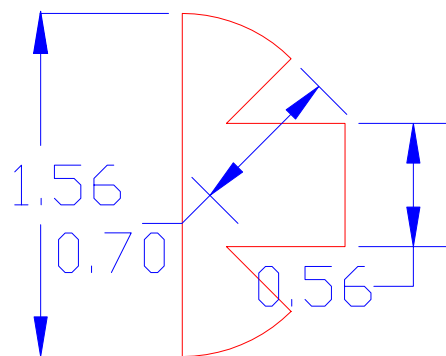

Once bonded the return losses are still at a reasonable level. They can be improved with a simple compensation network. The figures also show the effect of this bondwire compensation network (brown diamonds). The network is shown at the end of this section.

PREFERRED ASSEMBLY INSTRUCTIONS:

GaAs devices are fragile and should be handled with great care. Specially designed collets should be used where possible.

The back of the die is metallised and the recommended mounting method is by the use of conductive epoxy or solder. If Conductive Epoxy is used it should be applied to the attachment surface uniformly and sparingly to avoid encroachment of epoxy on to the top face of the die and ideally should not exceed half the chip height. For automated and manual dispense Ablebond 8350M is recommended. Ablestick 84-1 can be used as an alternative. These should be cured at a temperature of 150°C for 1 hour in an oven especially set aside for epoxy curing only. If possible the curing oven should be flushed with dry nitrogen.

This part has gold (Au) bond pads requiring the use of gold (99.99% pure) bondwire. It is recommended that 25.4µm diameter gold wire is used. For thermosonic ball bonding a nominal stage temperature of 150°C and a bonding force of 40g has been shown to give effective results for 25µm wire. Ultrasonic energy shall be kept to a minimum. For this bonding technique, stage temperature should not be raised above 200°C and bond force should not be raised above 60g. Thermosonic wedge bonding and thermocompression wedge bonding can also be used to achieve good wire bonds.

Bonds should be made from the die first and then to the mounting substrate or package. The physical length of the bondwires should be minimised especially when making RF or ground connections.

HANDLING PRECAUTIONS:

To avoid damage to the devices care should be exercised during handling. Proper Electrostatic Discharge (ESD) precautions should be observed at all stages of storage, handling, assembly, and testing. These devices should be treated as Class 0 (0-250 V) as defined in JEDEC Standard No. 22-A114. Further information on ESD control measures can be found in MIL-STD-1686 and MIL-HDBK-263.

APPLICATION NOTES & DESIGN DATA:

Application Notes and design data including S-parameters, noise data and large-signal models are available on request.

DISCLAIMERS:

This product is not designed for use in any space based or life sustaining/supporting equipment.

ORDERING INFORMATION:

PART NUMBER	DESCRIPTION
FMA3011	Die in Waffle-pack (Gel-pak available on request)