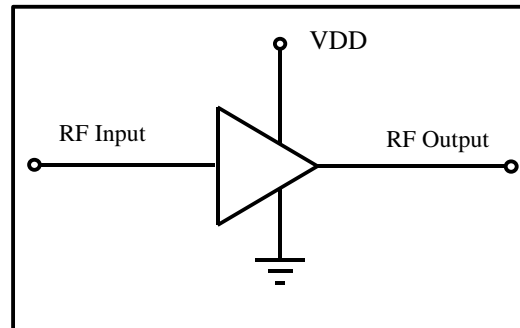

**12.7-16GHz MMIC LIMITING AMPLIFIER**
**FEATURES:**

- Self-Biased
- Single Supply
- 32dB Gain
- 17dBm Output
- pHEMT Technology
- Input Return Loss < -15dB
- Output Return Loss < -12dB

**GENERAL DESCRIPTION:**

The FMA3014 is a high performance 12.7-16GHz Gallium Arsenide monolithic amplifier. It is suitable for use in broadband communication and electronic warfare applications. The FMA3014 is ideally suited as a limiting amplifier where output power is invariant of input power. An example is the reduction of variability of mixer conversion loss to input LO drive level.

**FUNCTIONAL SCHEMATIC:**

**TYPICAL APPLICATIONS:**

- Electronic Warfare
- Broadband Communication Infrastructure
- Cellular Backhaul
- Point to Point Radio

**ELECTRICAL SPECIFICATIONS:**

PARAMETER	CONDITIONS (VDD=4.5V, ID=100mA)	MIN	TYP	MAX	UNITS
Small Signal Gain	12.7-16GHz	28	32		dB
Input Return Loss	12.7-16GHz	-8	-15		dB
Output Return Loss	12.7-16GHz	-8	-12		dB
Output Power at 1dB compression point	12.7-16GHz	13	15		dBm
Saturated Output Power	12.7-16GHz	15	17		dBm
Noise Figure	12.7-16GHz		6	7	dB
Self-bias Current	Small signal		100	130	mA

Note: T<sub>AMBIENT</sub> = +25°C, Z<sub>0</sub> = 50Ω

**ABSOLUTE MAXIMUM RATINGS:**

PARAMETER	SYMBOL	ABSOLUTE MAXIMUM
Max Input Power	Pin	+20dBm
Gate Voltage	VG1	Not Required
Drain Voltage	VDD	+6V
Operating Temp	Toper	-40°C to +85°C
Storage Temp	Tstor	-55°C to +150°C

**Note:**

Exceeding any one of these absolute maximum ratings may cause permanent damage to the device.

**PAD LAYOUT:**

PAD REF	PAD NAME	DESCRIPTION	PIN COORDINATES (μm)
A	I	RF in	(97,961)
B	B	1st and 2nd stage drain	(1206,1248)
C	D	3rd and 4th stage drain	(2166,1248)
D	O	RF out	(2904,550)
E	E	4th stage bias adjust	(2721,102)
F	F	Ground for pad E	(2467,102)
G	G	3rd stage bias adjust	(1957,102)
H	H	Ground for pad G	(1703,102)
I	J	2nd stage bias adjust	(1225,102)
J	K	Ground for pad I	(1061,102)
K	L	1st stage bias adjust	(636,102)
L	M	Ground for pad K	(472,102)

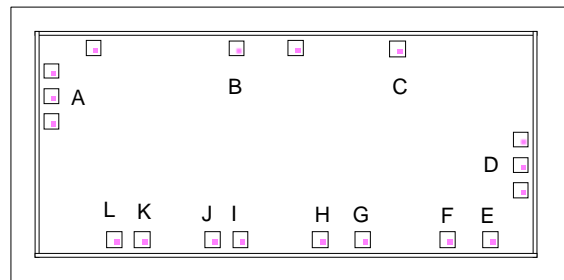

Note: Co-ordinates are referenced from the bottom left hand corner of the die to the centre of bond pad opening. Pads without identifiers are ground connections used in wafer testing.

DIE SIZE (μm)	DIE THICKNESS (μm)	MIN. BOND PAD PITCH (μm)	MIN. BOND PAD OPENING (μm x μm)
3000 x 1348	100	164μm	100 x 100

**TYPICAL PERFORMANCE FOR ON WAFER MEASUREMENTS:**

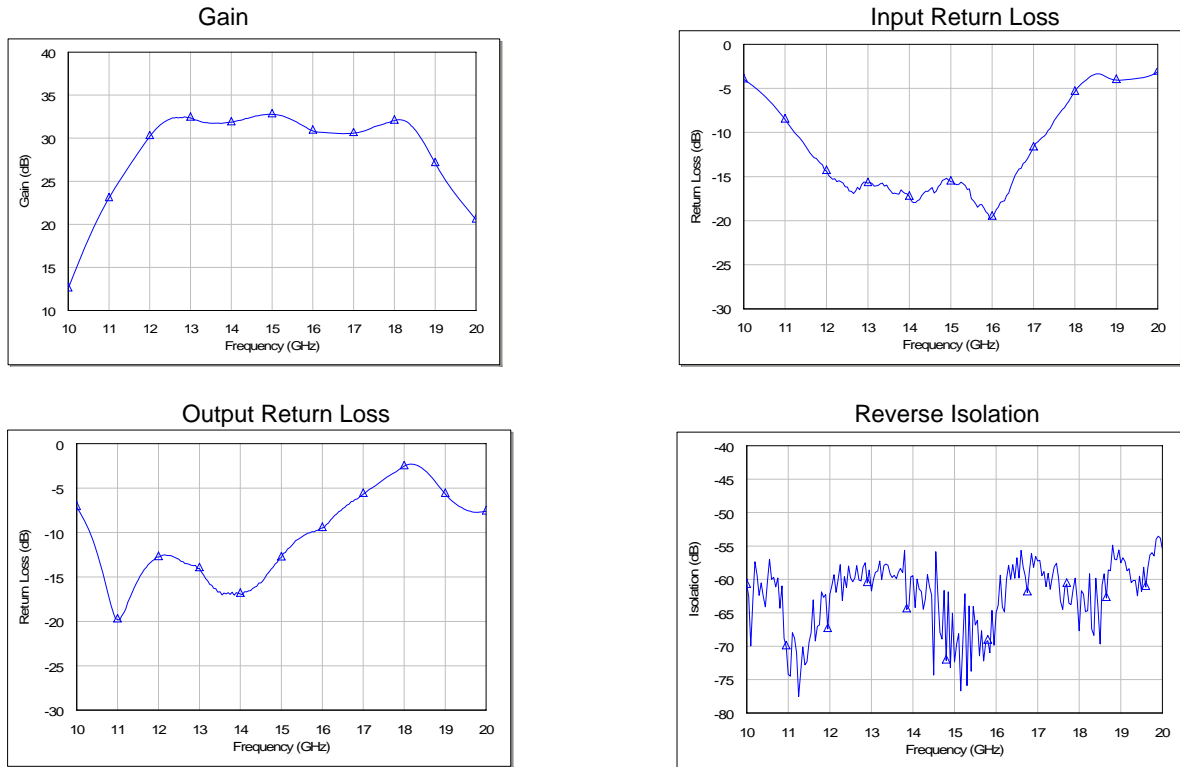
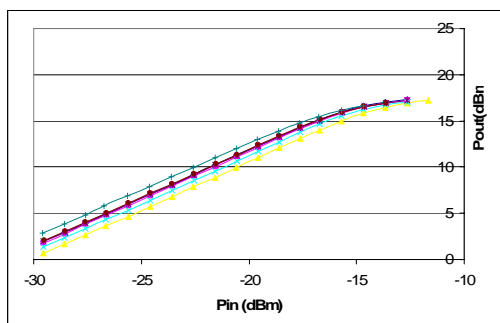
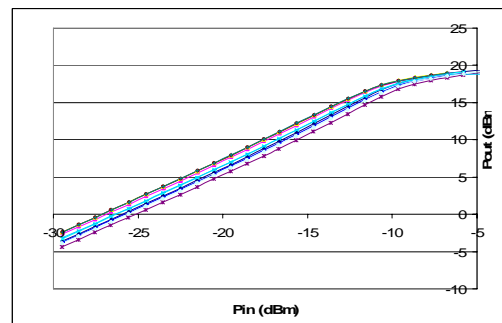
 Note: Measurement Conditions  $I_D = 110\text{mA}$ ,  $V_{DD} = 4.5\text{V}$ ,  $T_{\text{AMBIENT}} = 25^\circ\text{C}$ 

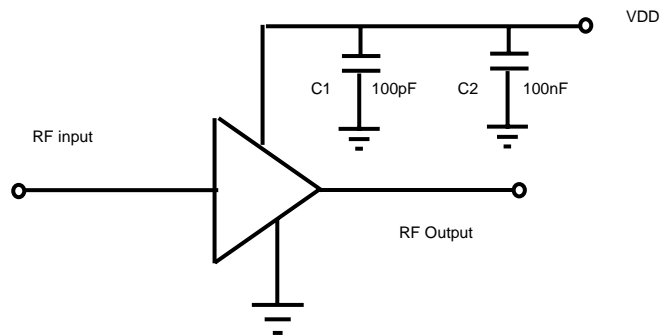
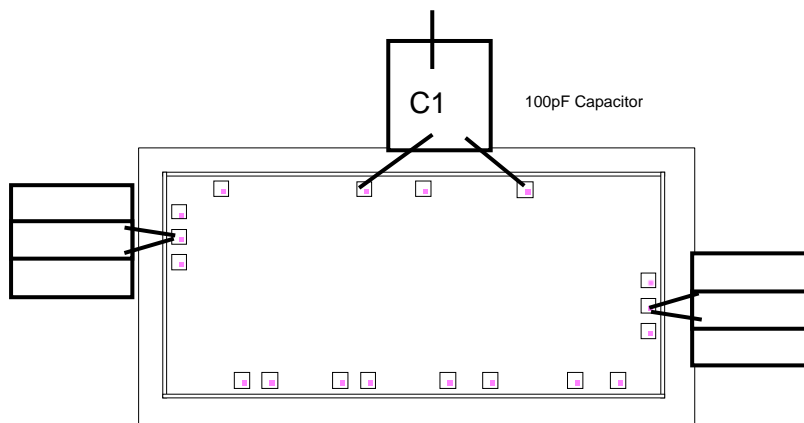
**TYPICAL MEASURED PERFORMANCE FOR 10 SITE ON WAFER POWER TRANSFER CHARACTERISTIC:**

 Note:  
 Measurement conditions:  $V_{DD} = 4.5\text{V}$   $I_D = 110\text{mA}$  (typ)

 Note:  
 Measurement conditions:  $V_{DD} = 6\text{V}$   $I_D = 110\text{mA}$  (typ)

**BIASING CIRCUIT SCHEMATIC:**

**Assembly Diagram:**

Note: Bond Wire length should be kept to a minimum

**BILL OF MATERIALS:**

LABEL	COMPONENT
Board	All RF tracks should be 50Ω characteristic material
C1	Capacitor, 100pF, chip capacitor
C2	Capacitor, 100nF, 0402

**EFFECT OF BONDWIRES AND BOND COMPENSATION:**

A pair of bondwires in the 'V' formation shown in the figure above, should if kept reasonably short, yield a combined inter-connect inductance of below 0.25nH. The FMA3014 has excellent return losses (blue triangles) and these are modified by the addition of a 0.25nH bondwire inductance (pink squares) as shown in the figures below.

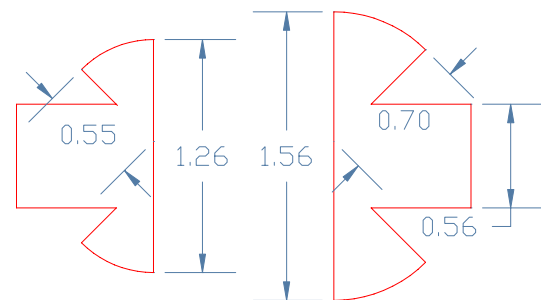
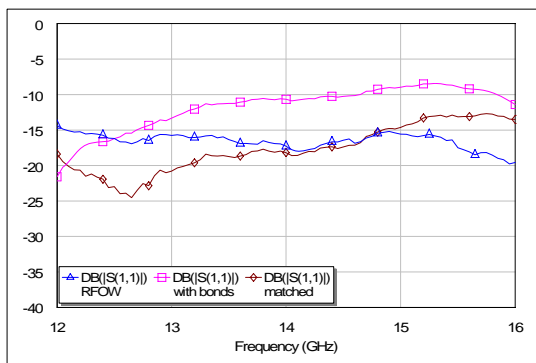
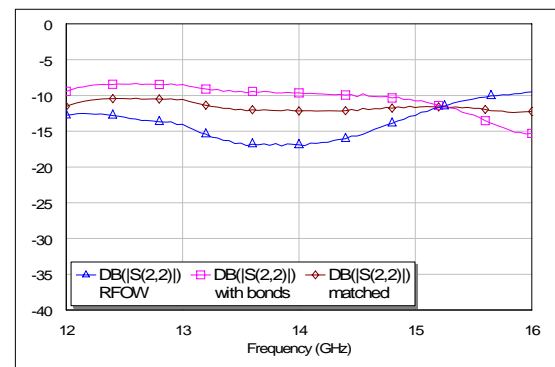
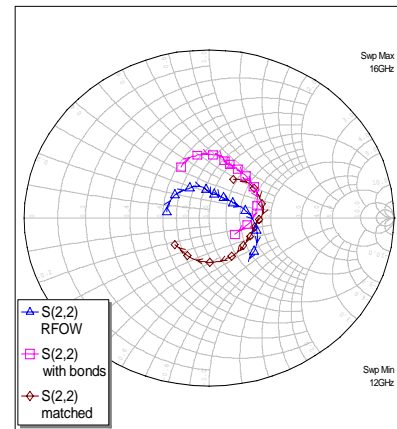
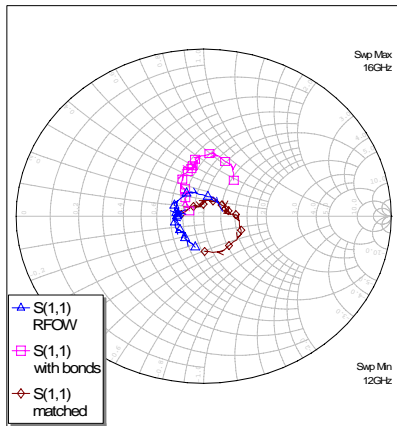

Input

Output

Dimensions in mm. Material is 10 thou 4350  
Er=3.38

**PREFERRED ASSEMBLY INSTRUCTIONS:**

GaAs devices are fragile and should be handled with great care. Specially designed collets should be used where possible.

The recommended die attach is gold/tin eutectic solder under a nitrogen atmosphere. Stage temperature should be 280-290°C; maximum time at temperature is one minute. The recommended wire bond method is thermo-compression wedge bonding with 0.7 or 1.0 mil (0.018 or 0.025 mm) gold wire. Stage temperature should be 250-260°C.

Bonds should be made from the die first and then to the mounting substrate or package. The physical length of the bondwires should be minimised especially when making RF or ground connections.

**HANDLING  
PRECAUTIONS:**

To avoid damage to the devices care should be exercised during handling. Proper Electrostatic Discharge (ESD) precautions should be observed at all stages of storage, handling, assembly, and testing. These devices should be treated as Class 1A (250-500V) as defined in JEDEC Standard No. 22-A114. Further information on ESD control measures can be found in MIL-STD-1686 and MIL-HDBK-263.

**APPLICATION NOTES & DESIGN DATA:**

Application Notes and design data including S-parameters, noise data and large-signal models are available on request.

**DISCLAIMERS:**

This product is not designed for use in any space based or life sustaining/supporting equipment.

**ORDERING INFORMATION:**

PART NUMBER	DESCRIPTION
FMA3014	Die in Waffle-pack (Gel-pak available on request)