

Specific request can be addressed to RAKON info@rakon.fr

Product Description

This Low Noise Oven Controlled Crystal Oscillator available in different footprints from 38x38x22 mm (1.5"x1.5"x0.8") till 25x22x12 mm (1"x0.8"x0.5"), is specifically designed to meet the request of the most demanding phase noise applications in the instrumentation and defence industries.

The LNO 100 @ 100 MHz can be provided with a guaranteed phase noise level of up to -165 dBc/Hz @ 1KHz and a g-sensitivity down to 0.5 ppb/g.

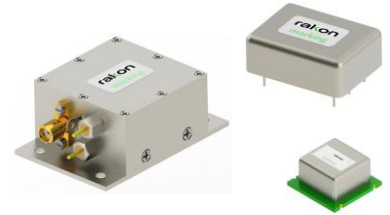

Features

- Low Noise Oscillator (LNO), Oven Controlled Crystal Oscillator (OCXO)
- Frequency: 80 to 125 MHz
- Guaranteed low phase noise @ 100 MHz:
 - 165 dBc/Hz @ 1kHz offset
 - 178 dBc/Hz @ 100kHz offset
- Supply Voltage: +12V & +15V
- Pin through hole, SMD package or with connectors
- Frequency Stability vs. Temperature: ± 0.2 ppm
- Ageing: ± 1.6 ppm over 10 years
- RoHS compliant

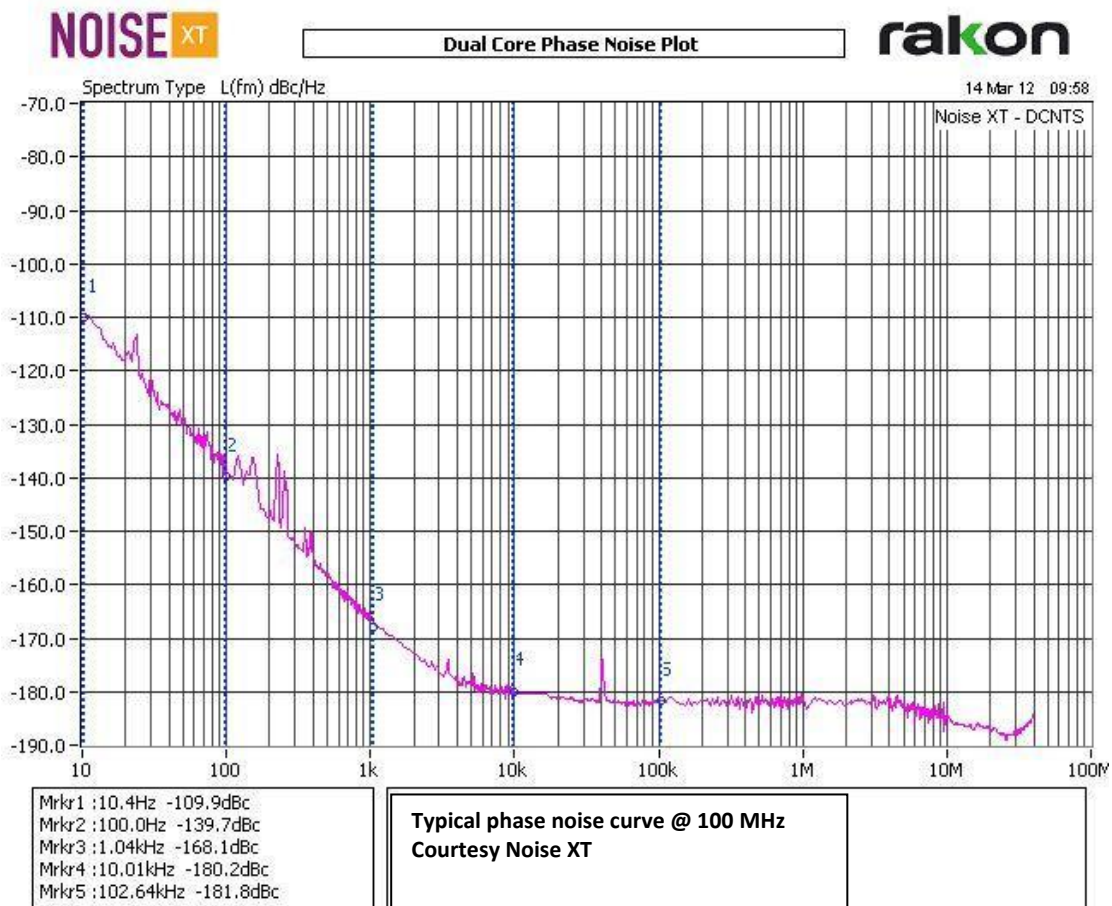

Applications

- Reference for phase noise measurement
- Test equipment
- Military communication
- Synthesizers
- Radar

Specifications

1. Environmental conditions

Parameters	Conditions/remarks	Min	Nom	Max	Unit
Operating Temperature	Option A	0	25	70	°C
	Option C	-40	25	85	°C
Switch-on Temperature	TSo	-40		85	°C
Storage temperature		-55		125	°C
Sine Vibration	Level as per MIL-PRF-28800F, Class 3, test equipment				
Shock	Level as per MIL-PRF-28800F, Class 3, test equipment				

2. Electrical interface

Parameters	Conditions/remarks	Min	Nom	Max	Unit
Power supply	Option 12	11.40	12	12.60	V
	Option 15	14.25	15	15.75	V
Load Impedance		45	50	55	Ω
Input impedance		10			κΩ

3. Performances





Parameters	Conditions/Remarks	Min	Typ	Max	Unit
Nominal Frequency		80		125	MHz
Relative pulling frequency range (positive slope)		± 1.8			ppm
Control voltage		0		10	V
Steady state input power	Typical @ 25°C			2.2	W
Warm up input power	Nominal frequency is achieved 5mn after start up @ 25°C			3.7	W
Initial frequency accuracy	@ 25°C			± 0.1	ppm
Frequency stability vs temperature	Option A (peak-peak) (0°C...70°C)			0.2	ppm
	Option C (-40°C...+85°C)			± 0.5	ppm
Frequency variation vs. supply voltage	Vcc ±5% @25°C			± 0.02	ppm
Frequency variation vs. load	For ±10% variation of load			± 0.02	ppm
Frequency ageing after 30 days of continuous operation	1st year			± 0.5	ppm
	10 years			± 1.6	ppm
Allan Variance	Tau=1s			± 5E-11	
	Tau= 10s			± 5E-10	
Frequency warm up	Time to be within the init. Freq. Accuracy compared to freq. After 1h			5	mn
G-sensitivity	Option SG: on the worst axis			± 2	ppb/g
	Option LG: on the worst axis (Lower g-sensitivity can be provided)			± 0.5	ppb/g
Output waveform		Sine			
Output level		11	13	15	dBm
Harmonics level				-25	dBc
Spurious level				-90	dBc
Modulation bandwidth		3			kHz

4. Minimum Guaranteed Phase Noise level

Frequency (MHz)	Performance level	100 Hz	1 KHz	10 KHz	100 KHz	Unit
80, 100, 120, 125	58	-130	-158	-172	-172	dBc/Hz
80, 100, 120, 125	62	-130	-162	-175	-175	dBc/Hz
100	65	-133	-165	-177	-178	dBc/Hz

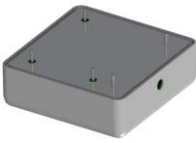
For performance levels at other frequencies, please consult your sales office.

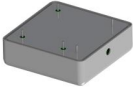
5. Mechanical features

Package name	Description	Dimensions		
PTH1	Pin Through Hole	1.5"x1.5"x0.5" 38x38x13 mm		
PTH2	Pin Through Hole "Europack"	1.5"x1"x0.5" 36x27x13 mm		
PTH3	Pin Through Hole	1"x1"x0.5" 25x25x13 mm		
PSS1	Pin Side+SMA	1.5"x1.5"x0.8" 38x38x22 mm		
SMD1	SMD	1"x0.8"x0.5" 25x22x12 mm		

5.1. Package PTH1 (Pin Through Hole)

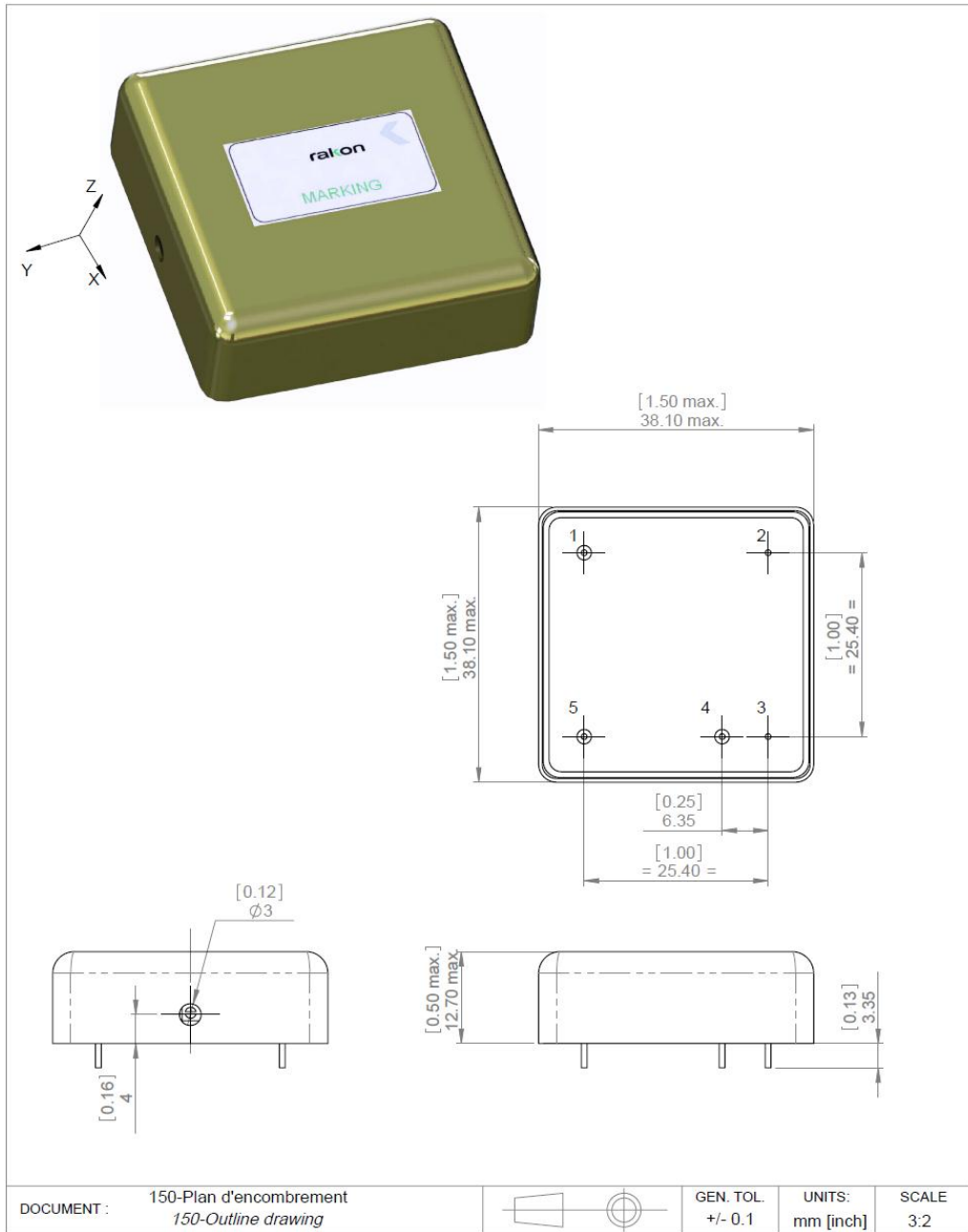

Pin number	Name	Description
1	Vcc	Supply voltage
2	GND	Electrical & mechanical ground
3	GND	Electrical & mechanical ground
4	Fout	Frequency output
5	Vc	Voltage control for electrical tuning

5.2. Package PTH2 (Pin Through Hole)

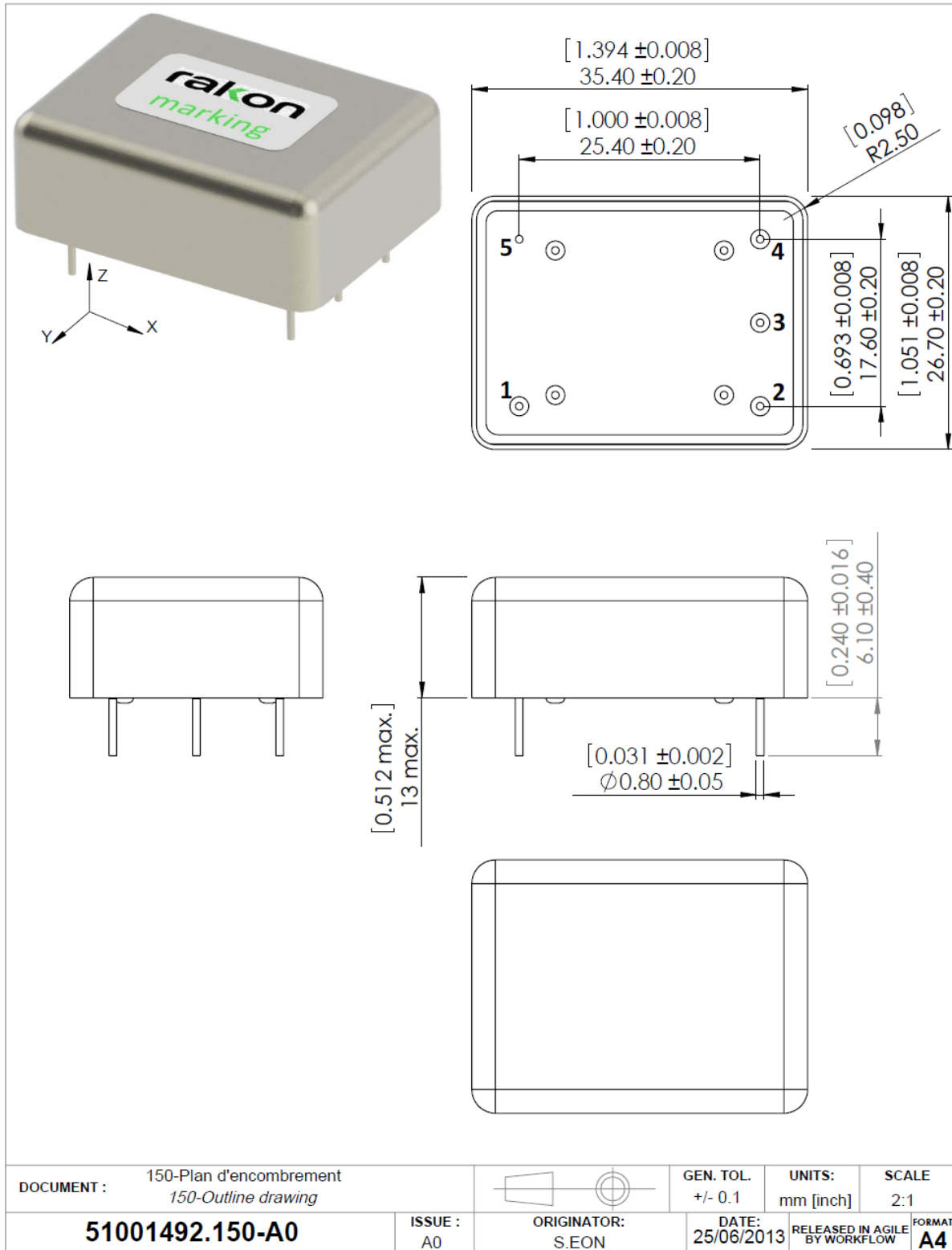

Pin number	Name	Description
1	Fout	Frequency output
2	Vcc	Supply voltage
3	N/C	Not connected
4	Vc	Voltage control for electrical tuning
5	GND	Electrical & mechanical ground

5.3. Package PTH3 (Pin Through Hole)

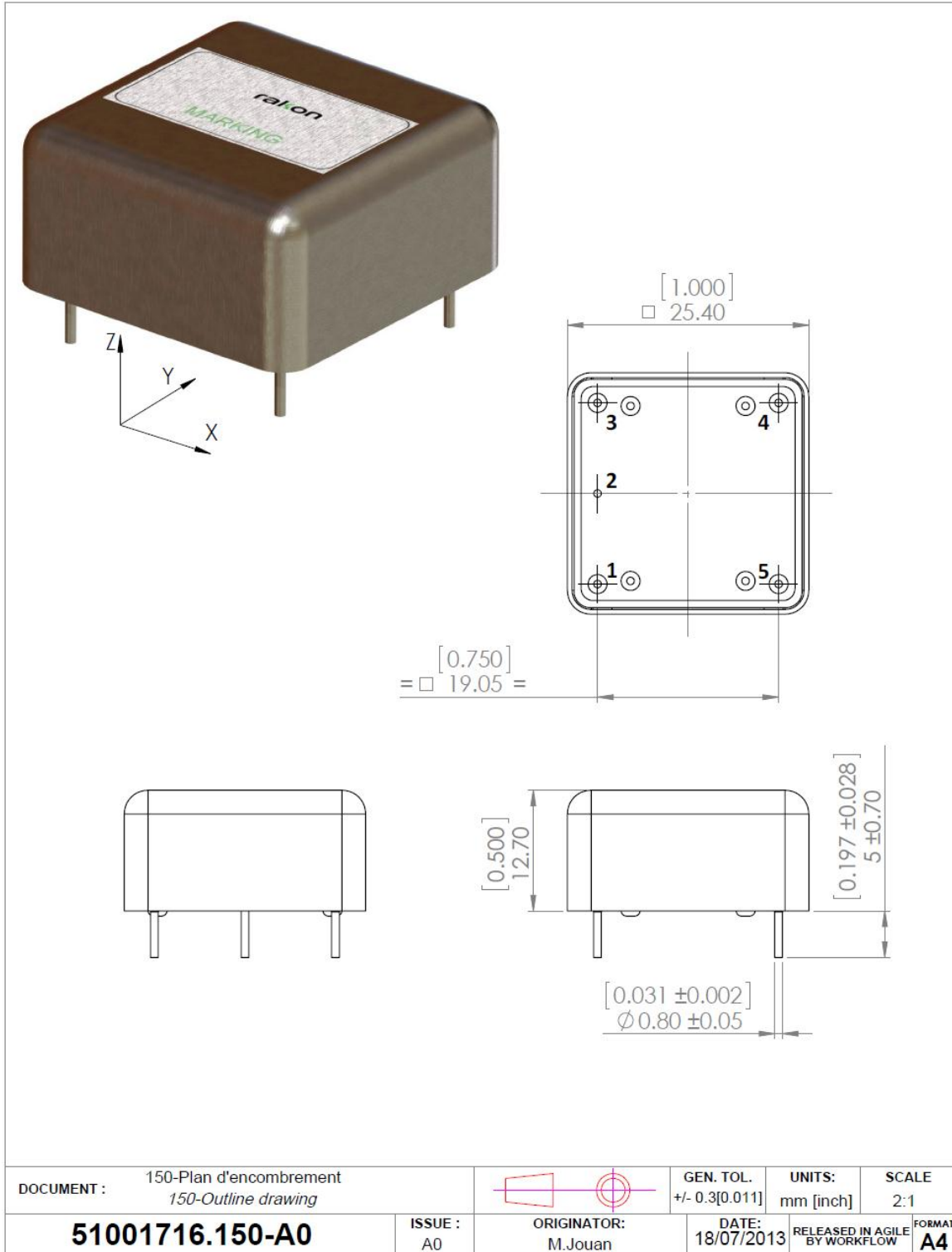

Pin number	Name	Description
1	Fout	Frequency output
2	GND	Electrical & mechanical ground
3	Vc	Voltage control for electrical tuning
4	GND	Electrical & mechanical ground
5	Vcc	Supply voltage

5.4. Package PSS1 (Pin Side+SMA)

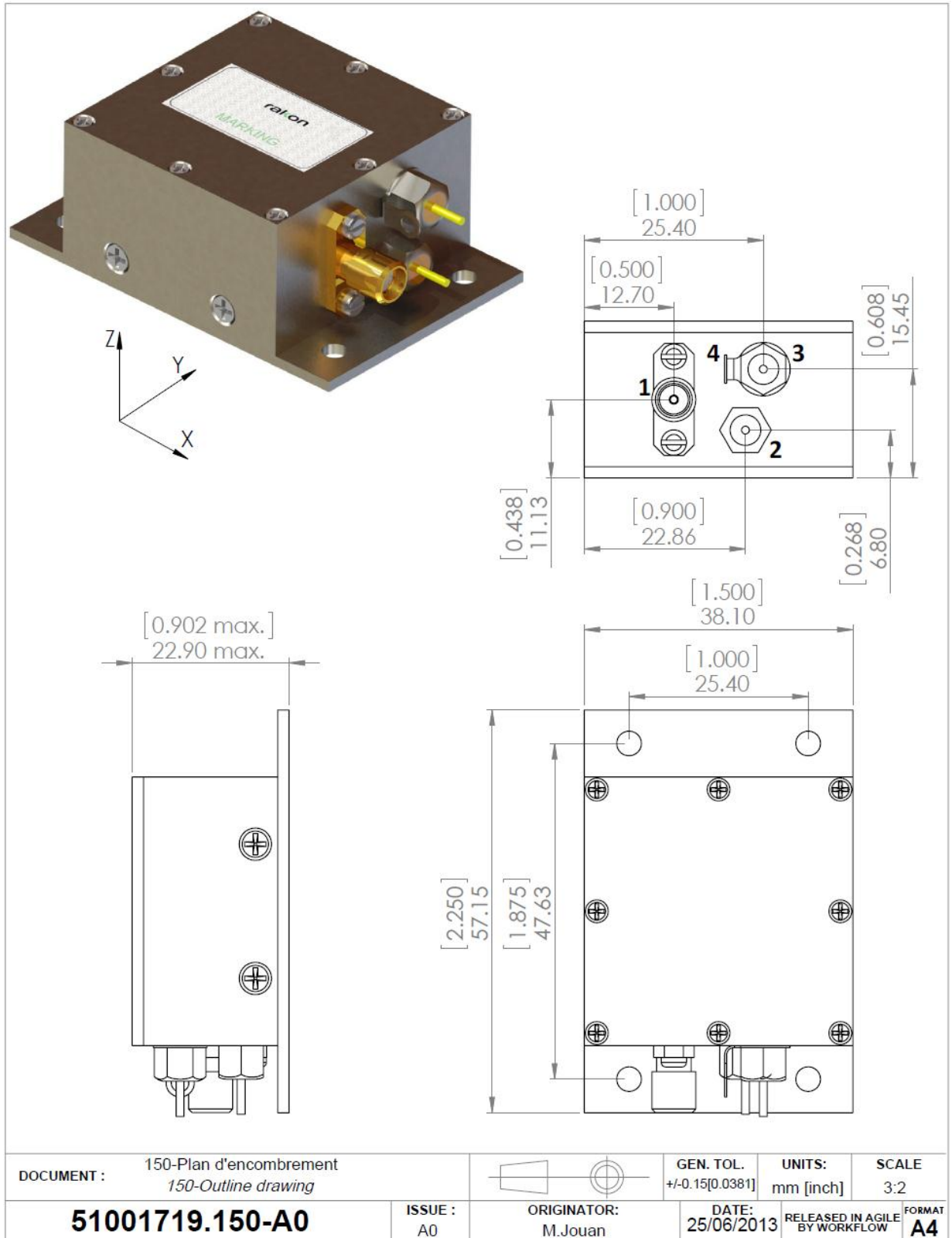

Pin number	Name	Function
1	Fout	Frequency output
2	Vc	Voltage control for electrical tuning
3	Vcc	Supply voltage
4	GND	Electrical & mechanical ground

5.5. Package SMD1 (Surface Mount Device)

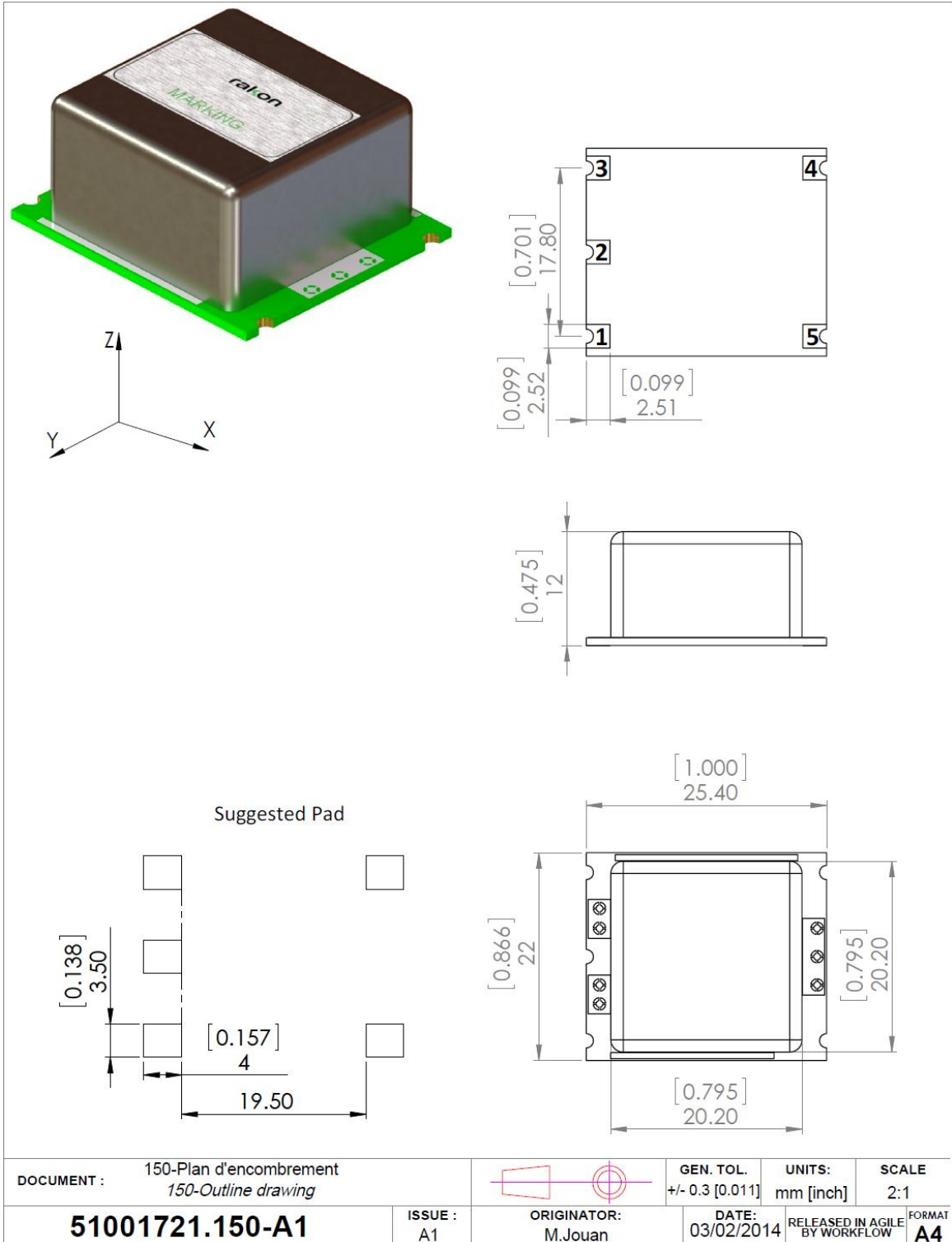

Pin number	Name	Description
1	Vc	Voltage Control
2	N/C	Not Connected
3	Vcc	Supply voltage
4	Fout	Frequency output
5	GND	Electrical & mechanical ground

6. Ordering part number definition

The part number breakdown is defined as follows:

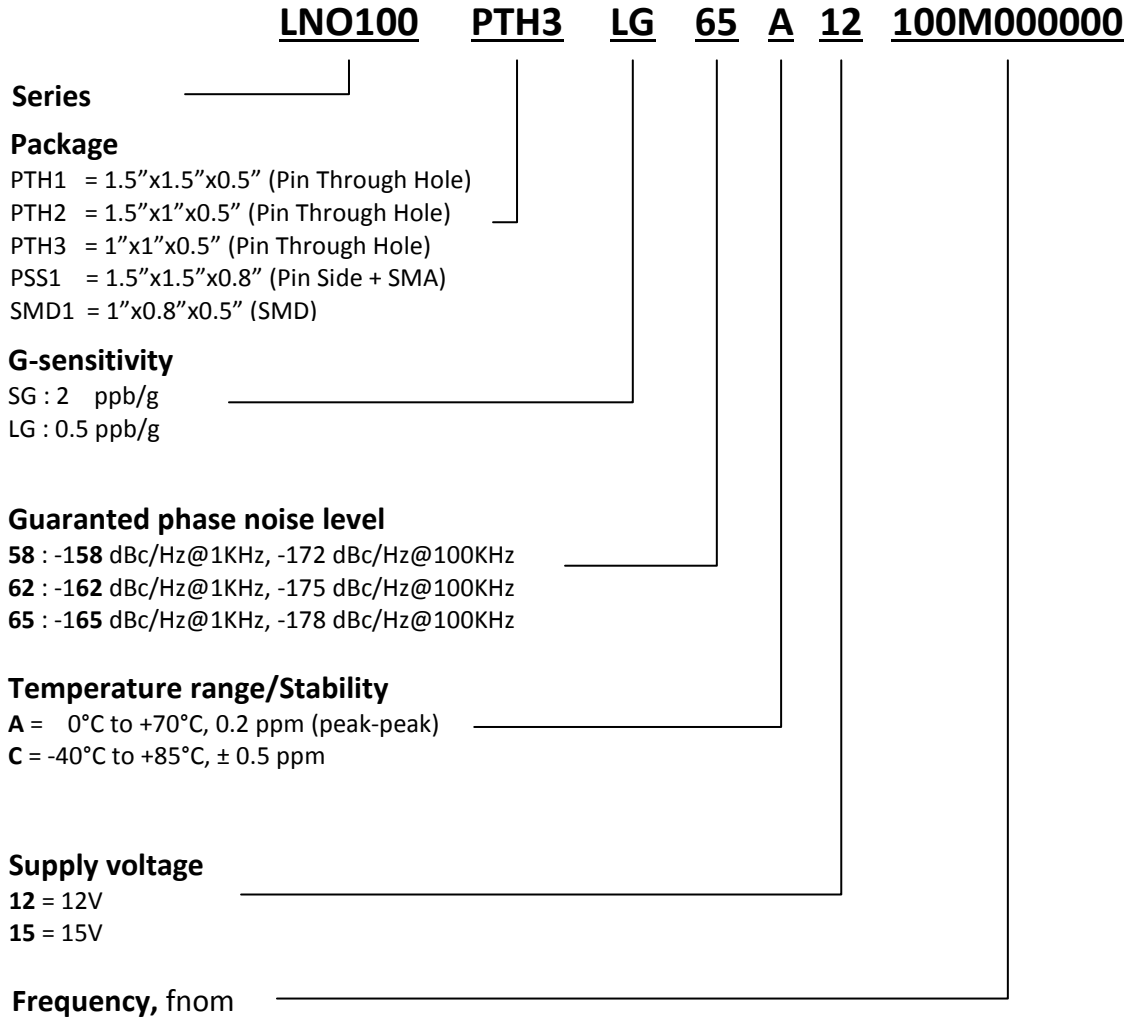

Standard frequencies: 80, 100, 120, 125MHz

LNOs with better ageing, better g-sensitivity can be provided.