

U7859LF

1.0 Specification References

Parameter	Description
a. Rakon part number	U7859LF
b. Description	ROM9070PA 10.0MHz MERC+ 9x7 HOT CMOS 3.3V
c. Version	A (2018-10-23) - PROVISIONAL
d. Package	L x W x H: 9.7 x 7.5 x 3.9 mm nom.



2.0 Absolute Maximum Ratings ¹

Parameter	Min.	Max.	Unit.
a. Storage temperature	-55	125	°C
b. Supply voltage (Vcc)	-0.5	6	V
c. Power dissipation		2	W
d. Load		50	pF

3.0 Frequency Characteristics ²

Parameter	Min.	Typ.	Max.	Unit	Test Condition / Description
a. Nominal frequency (Fn)		10.0		MHz	
b. Frequency calibration			±0.5	ppm	At 25°C ± 2°C, at time of shipment, reference to nominal frequency
c. Reflow shift			±0.4	ppm	After 1 hour recovery at 25°C
d. Operating temperature range	-40		+95	°C	
e. Frequency stability over temperature in still air			±20	ppb	Reference to (F _{MAX} + F _{MIN})/2
f. Frequency slope ΔF/ΔT in still air			±1.5	ppb/°C	Temperature ramp ≤ 1°C/minute
g. Supply voltage stability		±5		ppb	±2% variation, reference to frequency at 3.3V
h. Load sensitivity		±5		ppb	±10% variation, reference to frequency at 15pF
i. Warm-up time ³		< 3		minutes	
j. Long term stability (aging)			±2 ±0.6 ±2	ppb ppm	Per day ⁴ First year 10 years

¹ Operating beyond this limit may result in change or permanent damage to the device.

² The characteristics of the component may be temporarily affected by the processes of assembly and soldering. The frequency specifications apply after 48 hours of continuous operation. Nominal conditions (T=25°C, Vcc=3.3V, C_{load}=15pF) apply unless otherwise stated.

³ Time needed for frequency to be within ±20ppb reference to frequency after 1 hour, at 25°C. Parameter is frequency, assembly and operating history dependent.

⁴ After 30 days of continuous operation.

4.0 Power Supply

Parameter	Min.	Typ.	Max.	Unit	Test Condition / Description
a. Supply voltage (Vcc)		3.3		V	±5%
b. Input power (Warm up)		1200	1500	mW	Vcc = 3.3V
c. Input power (Steady state in still air at 25°C)		440	500	mW	Vcc = 3.3V

5.0 Oscillator Output – CMOS

Parameter	Min.	Typ.	Max.	Unit	Test Condition / Description
a. Output voltage level low (V _{OL})			10% Vcc	V	
b. Output voltage level high (V _{OH})	90% Vcc			V	
c. Rise and fall time		1	2	ns	10% to 90% level
d. Duty cycle	45		55	%	At 50% level
e. Load		15		pF	Nominal

f. Waveform screenshot (Example at 20MHz)

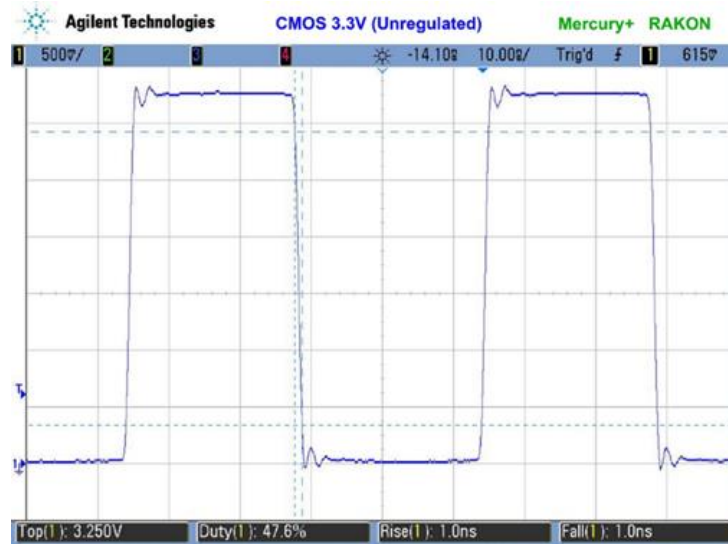

6.0 SSB Phase Noise (at 25°C)

Parameter	Typ.	Unit.	Test Condition / Description
a. 1Hz offset	-78	dBc/Hz	
b. 10Hz offset	-110	dBc/Hz	
c. 100Hz offset	-140	dBc/Hz	
d. 1kHz offset	-156	dBc/Hz	
e. 10kHz offset	-158	dBc/Hz	
f. 100kHz offset	-158	dBc/Hz	
g. 1MHz offset	-158	dBc/Hz	

7.0 Marking

Parameter	Description
a. Line 1 (Embossed)	rakon
b. Line 2 (Laser marked)	[R FFFF YM] Rakon identifier R, Frequency FFFF (M=MHz, e.g. 10M0=10.0MHz), Year Y (A=2010, B=2011, ...), Month M (1=Jan, 2=Feb, ..., A=Oct, B=Nov, C=Dec)
c. Line 3 (Embossed and Laser marked)	[• LLL] Pin 1 • (embossed), Lot code LLL (laser marked)

8.0 Manufacturing Information

Parameter	Description
a. Reflow soldering	IPC/JEDEC J-STD-020 (see Pb-free solder reflow profile)
b. Packaging description	Tape & Reel (see drawing)
c. Application note	For optimum performance follow the instructions in Mercury™ and Mercury+™ miniature OCXO application note

9.0 Environmental Specification ⁵

Parameter	Description
a. RoHS	Parts are fully compliant with the European Union directives 2002/95/EC and 2011/65/EU on the restriction of the use of certain hazardous substances in electrical and electronic equipment. Note these RoHS compliant parts are suitable for assembly using both Lead-free solders and Tin / Lead solders
b. Solderability	IPC/ECA J-STD-002, method 2, precondition 150°C, 16 hours
c. Latch Up	EIA/JESD78, tested at room temperature and maximum ambient operating temperature
d. Electrostatic Discharge (ESD)	Human Body Model (HBM), JEDEC JS-001-2012, ≥ 2000V Charged Device Model (CDM), JESD22-C101, ≥ 1000V Machine Model (MM), JESD22-A115, ≥ 200V
e. Low Temperature Storage	JESD22-A119, 1000 hours at -55°C, unbiased
f. Thermal Shock	JESD22-A104 / MIL-STD-883, method 1010, 15 cycles from -55°C to 125°C
g. Temperature Humidity Bias	EIA/JESD22-A101-B, 85°C / 85% RH, 1008 hours, at max. Vcc
h. Temperature Cycling	JESD22-A104 / MIL-STD-883, method 1010, 1000 cycles, -55°C to +125°C, non-operating, 15 minute soak
i. High Temperature Operating Life	JESD22-A108, ≥ 2000 hours at 125°C & max. Vcc
j. Cold Power Cycling	Rakon standard, -40°C, 12 minutes OFF, 4 minutes ON, 1000 cycles
k. Frequency Aging	MIL-PRF-55310, 1008 hours
l. Mechanical Shock	MIL-STD-202 (method 213), 1500g, 0.5ms duration, 18 shocks total
m. Vibration	JESD22-B103 (section 4.2.2), test Fc: 20g, 20 to 2000Hz, 4 minute sweep, 4 sweeps x 3 axes

⁵ For all relevant tests the units are pre-conditioned as per JESD22-A113 (5 temperature cycles -40°C to +60°C + bake for 24 hours at T = +125°C + moisture soak for 168 hours at +85°C / 85% RH + 3x reflow at T_{MAX} = +260°C).

10.0 Model Outline:

MODEL DRAWING

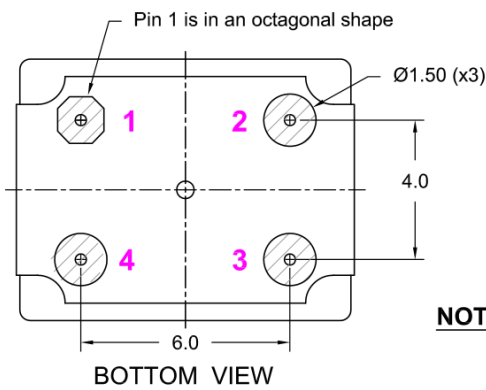
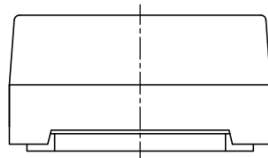
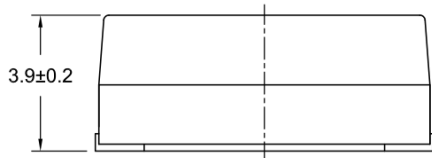
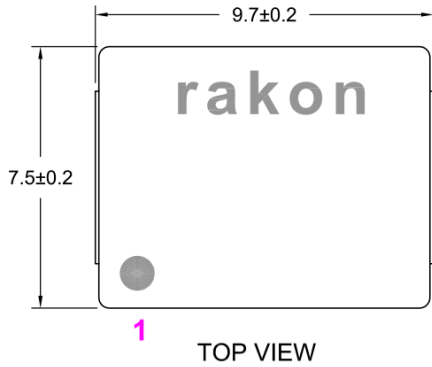

RECOMMENDED PAD LAYOUT - TOP VIEW

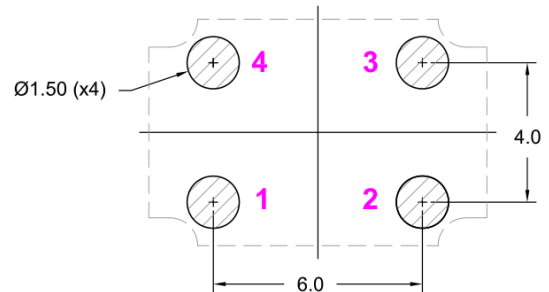

Pin Connections

Pin	Connections
1	Do not connect (GND optional)
2	GND
3	Output
4	Supply Voltage (Vcc) <i>for correct operation decouple the supply voltage with a 10 µF capacitor close to the oscillator</i>

- NOTE:**
- Cover: Plastic
 - Base: FR4
 - Finish: 0.05 ~ 0.13 µm Gold over 3 ~ 6 µm Nickel.

TEST CIRCUIT:

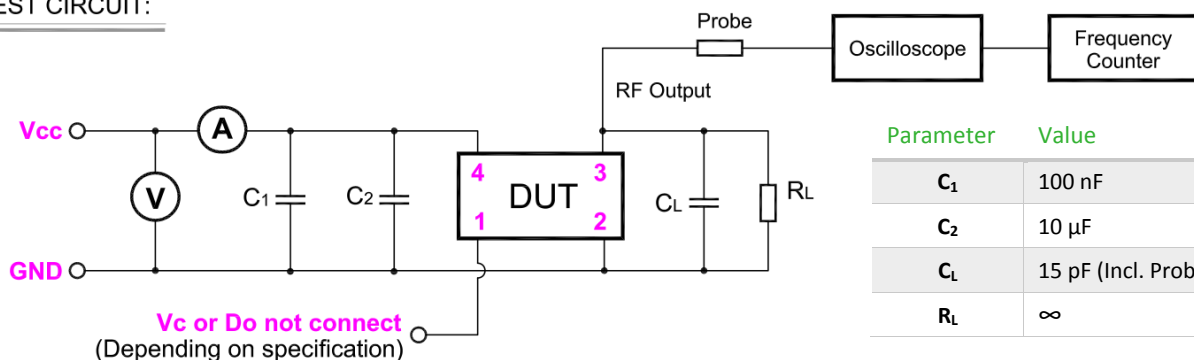

Parameter Value

Parameter	Value
C ₁	100 nF
C ₂	10 µF
C _L	15 pF (Incl. Probe)
R _L	∞

TITLE: ROM9070 Mercury+™ IC OCXO (Non-Hermetic)

FILENAME: CAT1054

TOLERANCES:

RELATED DRAWINGS:

REVISION: C

XX =

DATE: 09-Jan-2018

X.X = ±0.2

SCALE:

X.XX = ±0.10

Millimetres

X.XXX = ±0.05

X° =

Hole =

11.0 Tape and Reel:

TAPE DETAILS

(Scale 2 : 1)

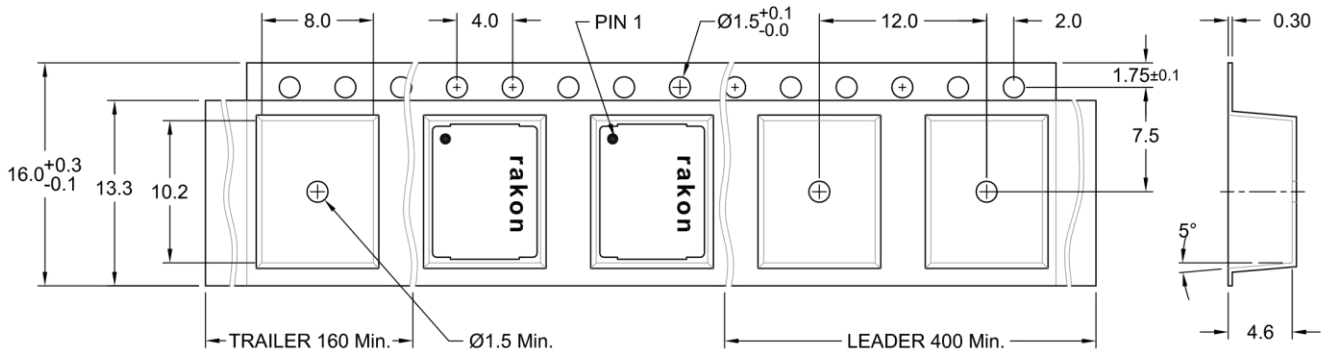

REEL DETAILS

(Scale 1 : 5)

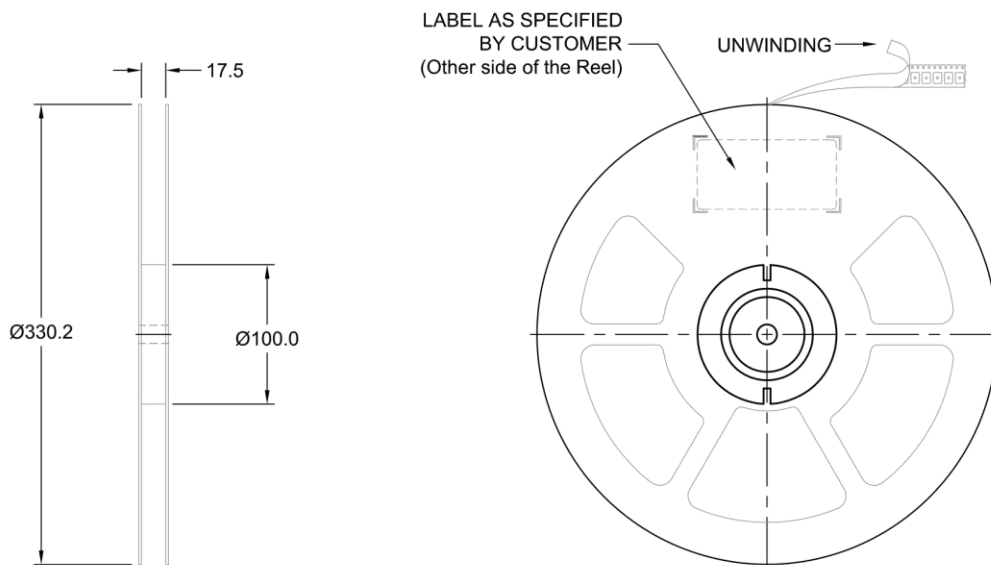

TITLE: 9070 Series Oscillators Tape & Reel

RELATED DRAWINGS:

FILENAME: CAT886

REVISION: B

DATE: 01-Mar-2017

SCALE:

Millimetres

TOLERANCES:

XX =

X.X = ± 0.1

X.XX = ± 0.05

X.XXX =

X° =

Hole =

rakon

© 2017 Rakon Limited

12.0 Reflow:

Pb-Free Reflow Soldering Profile *

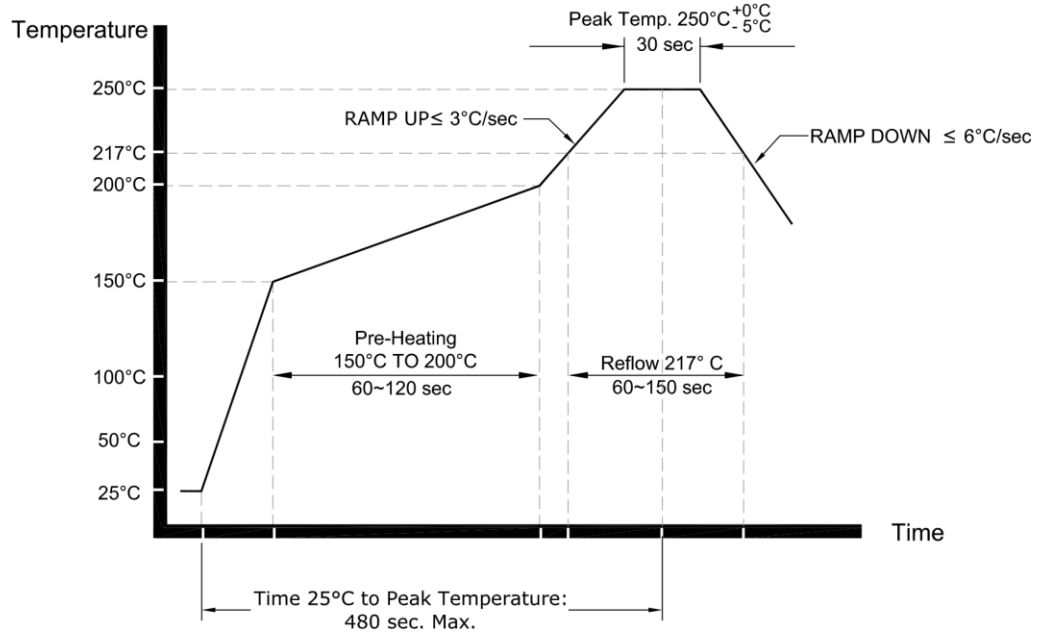

*** NOTE:**

These profile were used during the qualification testing of the product and therefore represents worst case conditions. It is not recommended for use by the customer in the actual assembly of these parts.

TITLE: Pb-FREE Miniture IC-OCXO Reflow

FILENAME: CAT1055

TOLERANCES:

RELATED DRAWINGS:

REVISION: A

XX =

DATE: 03-Mar-2017

X.X =

SCALE: NTS

X.XX =

Millimetres

X.XXX =

X° =

Hole =

rakon

© 2017 Rakon Limited

13.0 Specification History

Version	User	Changes	Approver	Date
A	JO	Initial issue	LX	2018-10-30

14.0 Disclaimer

Parameter	Description
a. Disclaimer	"Samples supplied according to this specification are supplied from our development or pre-production programme and as such are not qualification approved products. No condition, warranty or representation regarding quality, suitability, performance, life or continuation of supply is given or implied and Guarantee in clause 6.1 of our standard Conditions of Sale is not applicable. The right is reserved to change the design or specification or cease supply without notice." RAKON Limited