

SPECIFICATIONS

ELECTRICAL
 FREQUENCY RANGE _____ DC-6, 12.4 AND 18GHz

VSWR
 DC - 6GHz _____ 1.25:1 MAX
 6 - 12.4GHz _____ 1.35:1 MAX
 12.4 - 18GHz _____ 1.45:1 MAX

INPUT POWER _____ 50 WATTS AVG. @ 25°C
 DERATED LINEARLY TO 10 WATTS @ 125°C

PEAK POWER _____ 500 WATTS
 (5uSec PULSE, .05% DUTY CYCLE)

IMPEDANCE _____ 50 OHMS

OPERATING TEMP RANGE _____ -65°C TO +125°C

MECHANICAL
 SMA CONNECTOR _____ PASSIVATED STAINLESS STEEL
 CONDUCTORS _____ GOLD PLATED BERYLLIUM COPPER
 HOUSING _____ BLACK ANODIZED ALUMINUM

TO DESIGNATE MAX FREQUENCY REPLACE "-FQ" WITH:
 '-06" = 6 GHz; "-12" = 12.4 GHz; "-18" = 18 GHz

MARKING:
 PART LOOKS LIKE PRODUCT IMAGE ABOVE.
 PART MARKING ORIENTATION AND FORMAT AS SHOWN.
 MARKING TO BE AS LARGE AS POSSIBLE, CLEAR, READABLE.
 YYWW EQUALS DATE CODE.

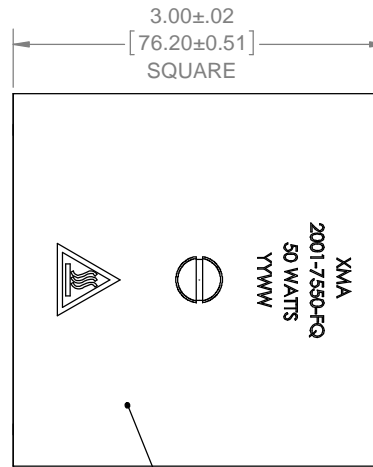
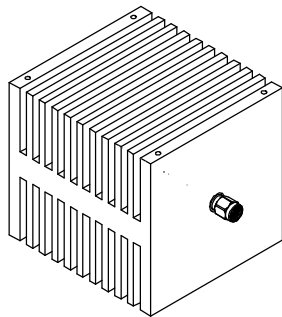

MARKING AREA
 SEE NOTE

REVISIONS				
REV	DESCRIPTION	ECO #	DATE	APPROVED
A	ADDED DIFF FREQ'S TO SINGLE DWG		8/18/08	T.KUHN
B	ADDED MARKING; UPDATE FORMAT	15-319	10/27/15	T.KUHN

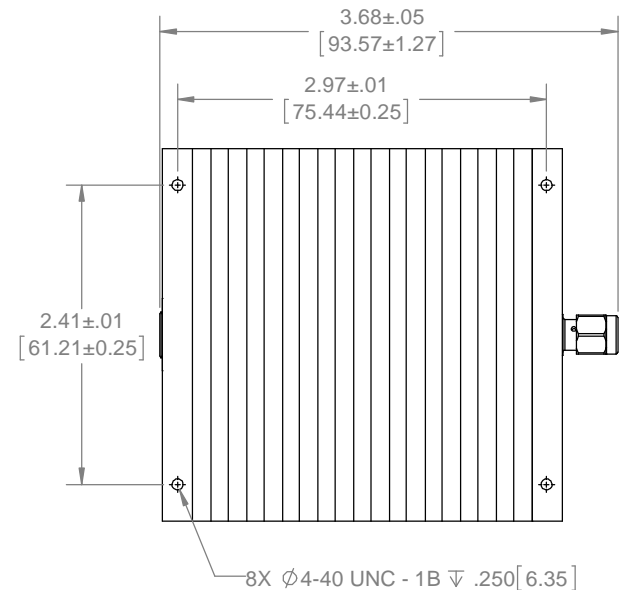

QTY.	PART NUMBER	DESCRIPTION	ITEM NO.
	2001-7550-FQ	TERMINATION, SMA-m, DC-18GHz, 50W	
1	TA-2001-7550-FQU	ASSY, TERMINATION, SMA-m, DC-18GHz, 50W, UNMARKED	1

DRAWING PRACTICES PER ANSI-Y-14.5 MIL-STD-100 & 1000	
DIMENSIONS ARE IN INCHES AND APPLY BEFORE / AFTER PROCESSING	
SURFACE ROUGHNESS μINCHES	63
FINISH:	
SEE NOTE	
MATERIAL:	
SEE NOTE	
NOTE: THIS DRAWING INCORPORATES THIRD ANGLE PROJECTION.	
INTERPRET IAW ANSI Y14.5-1982	

UNLESS OTHERWISE SPECIFIED TOLERANCES IN:	
DECIMALS	INCH (MM)
.X"	.05" [1.27]
.XX"	.03" [.76]
.XXX"	.010" [.25]
ANGLES ±0°30'	
REMOVE ALL BURRS/SHARP W/ BREAK / R OF .003" TO .0005" UNLESS OTHERWISE NOTED	
DIAS CONCENTRIC <.003 T.I.R.	
DO NOT SCALE PRINT	

DRAWN	DATE
T.KUHN	02/13/07
CHECKED	DATE
ENG. APPR.	DATE
T.KUHN	02/13/07
THESE DRAWINGS AND SPECIFICATIONS ARE THE PROPERTY OF XMA CORP. OR OMNI SPECTRA AND SHALL NOT BE REPRODUCED, COPIED NOR USED - IN WHOLE OR IN PART - AS A BASIS FOR THE MANUFACTURE OR SALE OF OTHER ITEMS WITHOUT THE EXPRESS WRITTEN PERMISSION OF XMA CORP.	

Phone: 603-222-2256 Fax: 603-222-2259
 150 Dow Street, Manchester, NH 03101

TITLE
TERMINATION, SMA-m, DC-18GHz, 50W

SIZE	CAGE CODE	DRAWING NUMBER	REV
B	3HT76	2001-7550-FQ	B
SCALE	PLATED AREA SQ. IN	SHEET 1 OF 1	